

# USER GUIDE

Solar kit & power meter

# Table of Contents

<b>01 Power Meter</b>	<b>01</b>
1.1 Safety Instructions	02
1.2 Safety & Installation Requirements	03
1.3 Product Overview	04
1.4 Technical Specifications	05
1.5 Package Contents	06
1.6 Assembly	08
1.7 Installation – General Setup	09
1.8 Installation – Breaker Box	11
1.9 Installation – CraftStrom App	12
<b>02 Solar kit</b>	<b>14</b>
2.1 Safety Instructions	15
2.2 Product Overvie	17
2.3 Technical Specifications – Solar Panels	19
2.4 Technical Specifications – Inverter	20
2.5 Package Contents	22
2.6 Installation – General Setup	24
2.7 Installation – Multiple Panels (System Expansion)	26
2.8 Installation – Stand	27
2.9 Installation – CraftStrom App	29
2.10 Power Flow & Communication	31

# 01

## POWER METER



## 1.1 Safety instructions

### **Installation of the power meter must be carried out by a qualified electrician.**

The symbols below are used throughout this manual to indicate different levels of potential risk and to draw attention to the severity and likelihood of hazards in each section.

#### **Caution**

Indicates a situation or action that may result in property damage or loss of data.

#### **Warning**

Indicates a hazardous situation that may result in serious injury or death.

#### **Notice**

Indicates important information, policies, or instructions that are not related to personal injury.

Safety notices indicate the level of danger. Safety instructions further describe the nature and cause of the hazard, the possible consequences, and the measures required to prevent or avoid it.

## Responsibilities

CraftStrom does not perform installations at the customer's premises.

The customer is responsible for reading and complying with all safety instructions contained in this user manual and for ensuring that installation is carried out by a qualified and certified electrician.

CraftStrom assumes no liability for the installation of this power meter.

## Safety Regulations

The following safety regulations must be strictly observed during installation, removal, or servicing of the Power Meter:

- All connections must be fully disconnected from any voltage source before installation or opening of the device.
- Contact with live electrical components is life threatening. Always remove the main fuses before starting work and store them securely to prevent unintentional re-connection.
- All applicable local safety regulations and electrical codes must be observed. Installation may only be carried out by technically qualified and properly trained personnel.
- Only suitable and properly insulated tools may be used. Ensure that tools are of the correct size and intended for electrical work.
- The Power Meter must be securely held during installation to prevent mechanical damage.
- Devices that have been dropped must not be installed, even if no external damage is visible. Such devices must be returned to CraftStrom for inspection, as internal damage may result in malfunction or short circuits.
- The Power Meter must never be cleaned with running water or compressed air. Ingress of water may cause short circuits or permanent damage.

## 1.2 Safety & Installation Requirements

### Hazard of Live Electrical Parts

The Power Meter is connected to live electrical systems. Contact with live components is life-threatening.

All safety instructions must be strictly observed at all times during installation and operation.

### Environmental Conditions for Installation

- **All our products require a single band 2.4 GHZ WiFi signal to install. Go to router settings and split signal by renaming the 2.4GHZ signal. Leave the 5G signal with old name. No spaces allowed in name or password.**
- The Power Meter may only be operated in a mechanical environment class M1, with negligible vibration and shock, in accordance with Directive 2014/32/EU.
- The device is designed for installation in an electromagnetic environment class E2, in accordance with Directive 2014/32/EU.
- The Power Meter is intended for indoor installation only, under non-condensing environmental conditions.
- If current transformer (CT) clamps are used outside of a standard DIN-rail meter enclosure, it must be ensured that all conductors remain freely accessible.

### This power meter is for indoor use only

Outdoor installation is not permitted unless unavoidable. In such cases, the Power Meter must be installed inside a suitable protective enclosure that maintains the specified operating conditions.

The enclosure must be properly sealed to protect the device from environmental influences, including extreme temperatures, humidity, and insect intrusion.

### Who is allowed to install?

Installation and operation of the Power Meter are permitted only under the following conditions:

- All work must be performed exclusively by qualified and appropriately trained personnel
- The installer must be familiar with and comply with all applicable local safety regulations and electrical codes
- Strict compliance with the instructions in the Safety Instructions section is mandatory, particularly those relating to safe operation
- Prior to installation, ensure that all required tools and materials are available

## 1.3 Product Overview

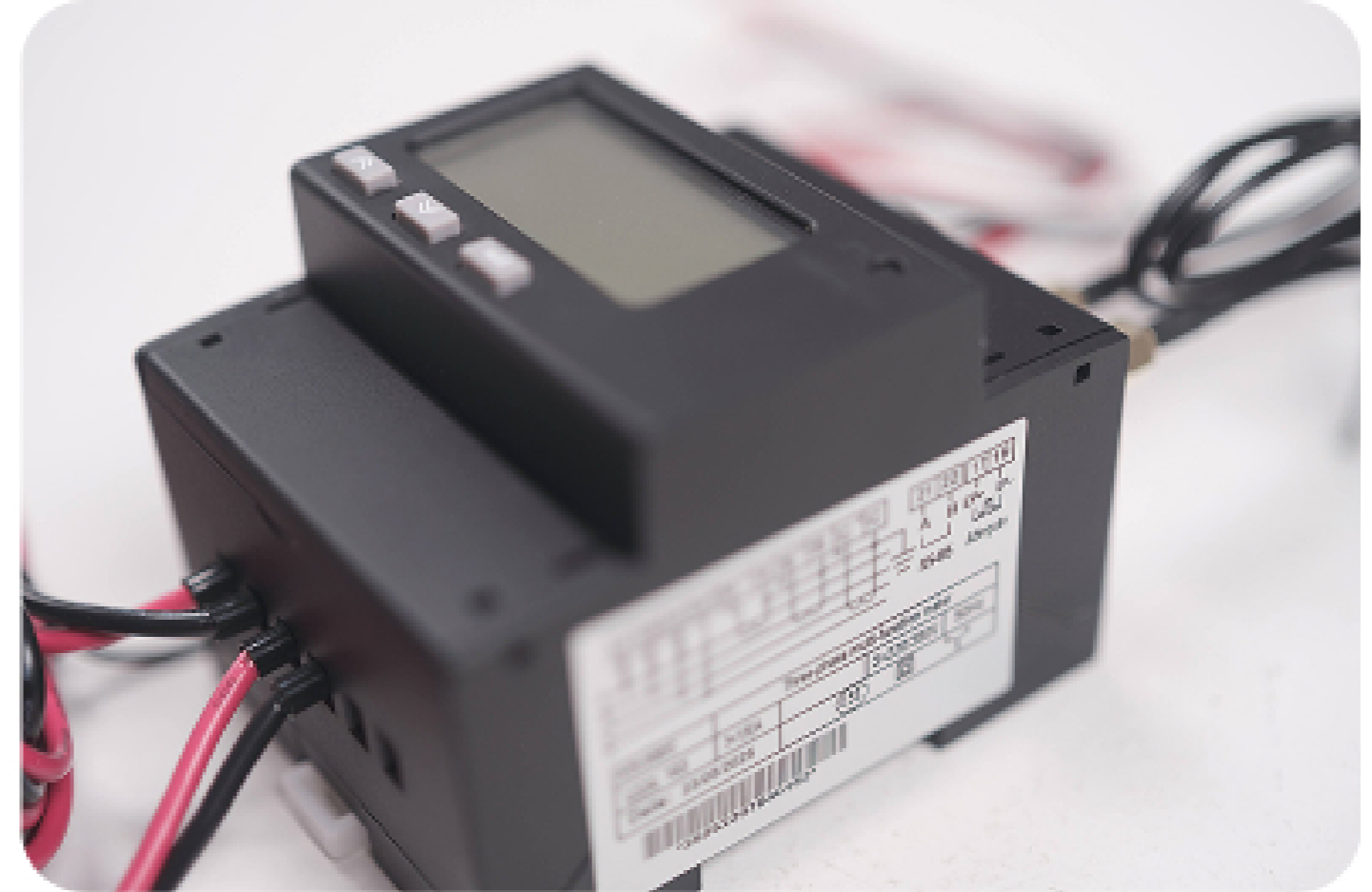
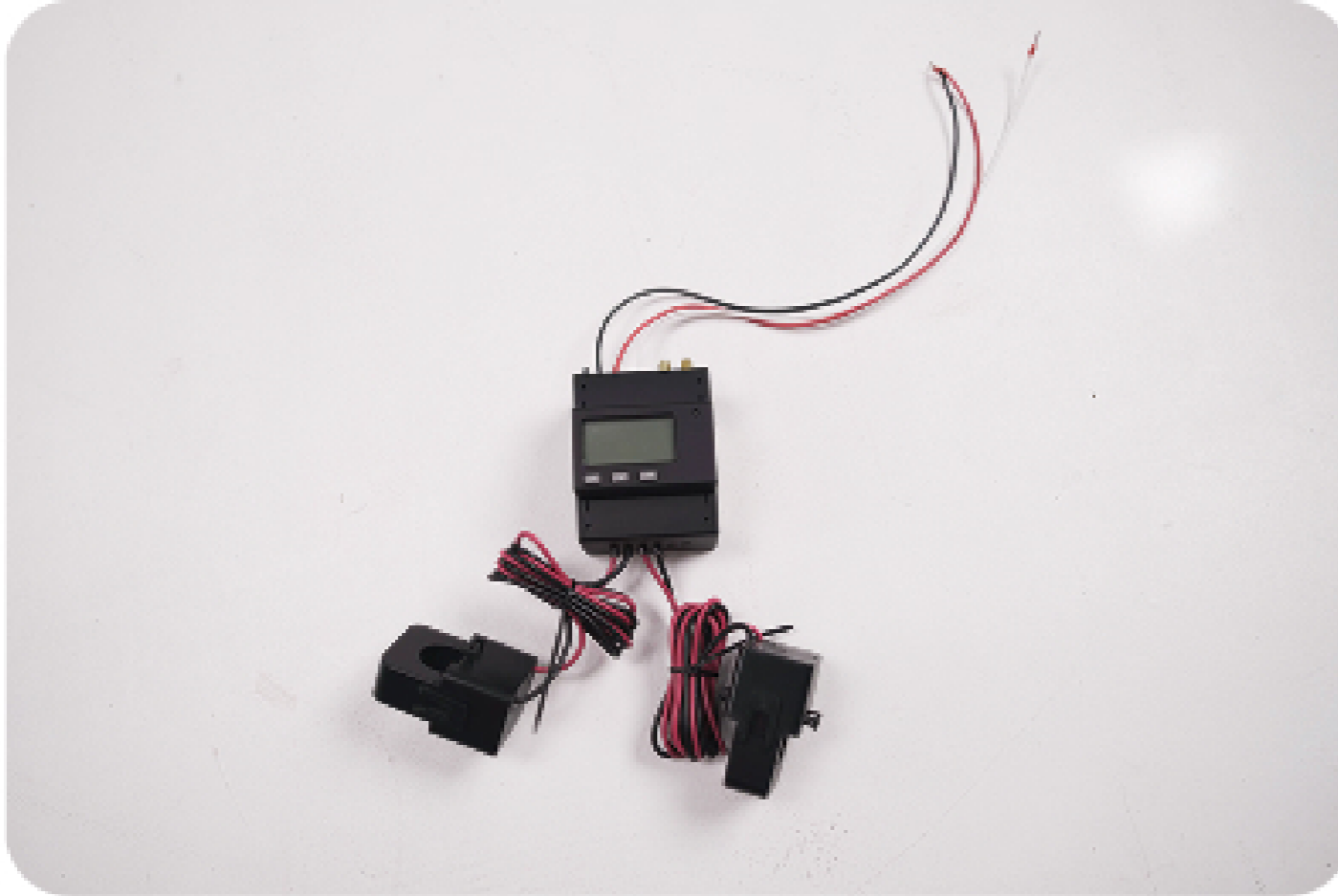

### Function

#### Bi-Directional Power Measurement

The Power Meter measures active power within the electrical circuit. Reactive power flows between the source and the load and may change direction depending on operating conditions.

Through bi-directional measurement, the Power Meter clearly distinguishes between electricity production and electricity consumption, enabling accurate monitoring of energy flow.

### Measured Parameters

- Voltage [U]
- Current [I]
- Active power [P]
- Reactive power [Q]
- Apparent power [S]
- Frequency [f]
- Power factor / phase shift [PF]

### Communication

The Power Meter is equipped with an integrated CraftStrom communication module for secure data transmission via:

- WiFi (2.4 GHz)
- Sub-GHz communication (433 MHz)

## 1.4 Technical Specifications

<b>Measurements – Voltage</b>	Reference voltage	3×100V, 3×380V, 3×57.7/100V, 3×220/380V
	Consumption	<10VA (Single phase)
	Impedance	>2MΩ
	Accuracy	±0.2%
<b>Measurements – Current</b>	Input current	3×1(6)A; 3×10(80)A
	Consumption	<1VA (Single circuit rated current)
	Accuracy	±0.2%
<b>Power</b>	Accuracy	±0.5%
<b>Mains frequency</b>	Range / accuracy	45~65Hz, ±0.2%
<b>Energy measurement</b>	Electrical energy	Active power (accuracy level 0.5S); Reactive power (accuracy level 2)
	Time measurement	≤0.5s/T
<b>Digital signal</b>	Electricity pulse output	1 channel optocoupler
<b>Pulse</b>	Pulse width	80±20ms
	Pulse constant	400imp/kWh, 10000imp/kW
<b>Communication</b>	Internal	RS485% Modbus RTU, DL/T645
	External	2.4 GHz (WiFi), 433 MHz
	Baudrate	1200bps~19200bps
<b>Environmental conditions</b>	Operating temperature range	-25°C ~ +55°C
	Humidity	≤95%

## 1.5 Package Contents

The CraftStrom Power Meter package contains:

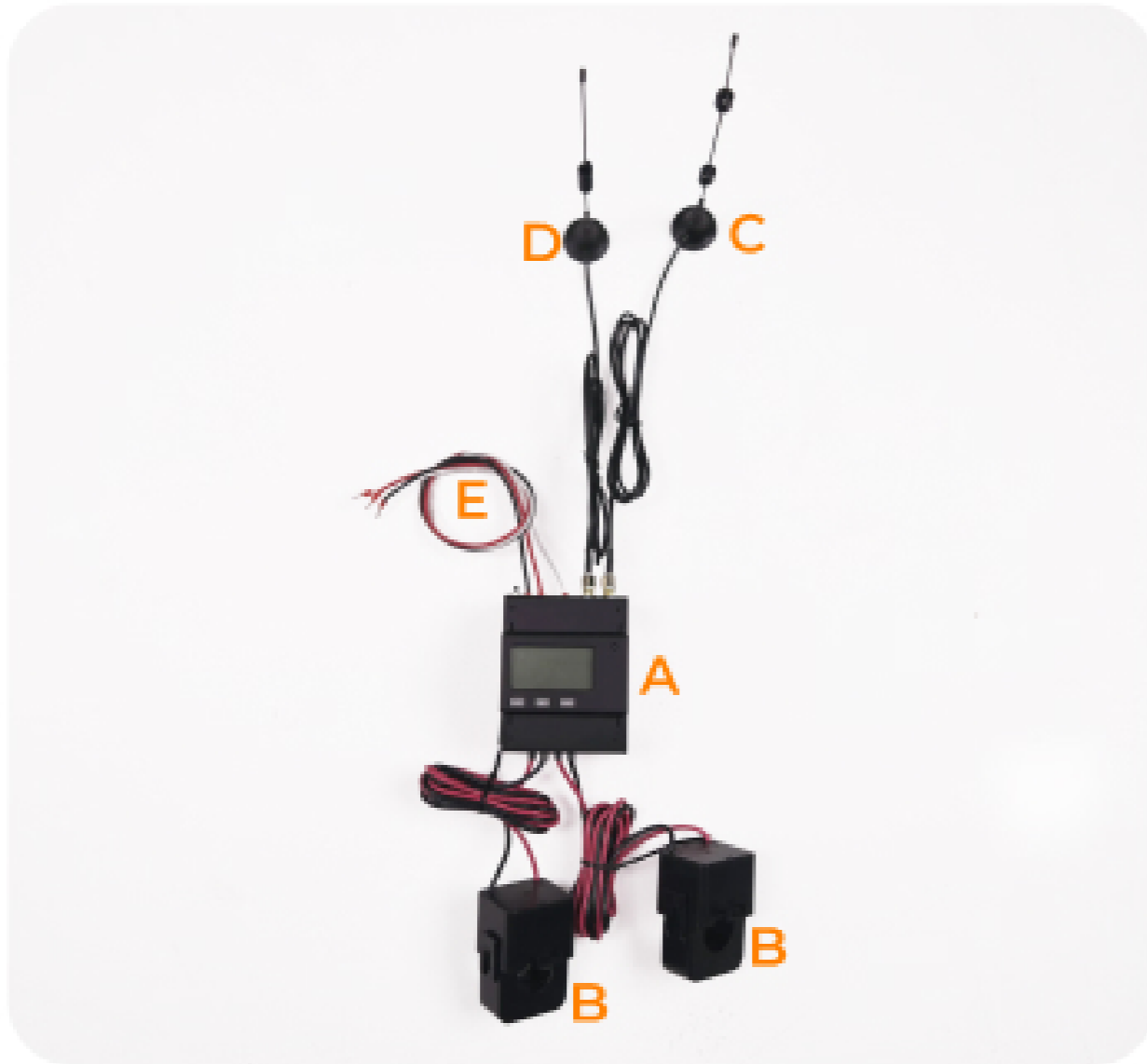

### A - Power Meter (Main Unit)

The main measuring device used for:

- bi-directional measurement of electricity consumption and production
- communication with CraftStrom inverters, batteries, and the CraftStrom app

The unit is designed for DIN-rail mounting inside the breaker box and includes:

- phase and neutral terminal connections
- current transformer (CT clamp) inputs
- a reset button
- antenna connectors

### B - Current Transformer Clamps (CT Clamps) – 2 pcs

Current Transformer Clamps (CT Clamps) – 2 pcs

Used to measure current on the main supply lines:

- L1 Clamp
- L2 Clamp

Each clamp includes:

- one red wire
- one black wire

### C - WiFi Antenna (2.4 GHz) – 1 pc

- Enables connection to the home WiFi network
- Identified by two coils
- Magnetic base for easy mounting inside the breaker box

### D - MHz Antenna (433 MHz) – 1 pc

- Enables sub-GHz communication between CraftStrom devices
- Identified by one coil
- Magnetic base for internal mounting

### E - Power cords

- These conductors are used to connect the Power Meter to the circuit breakers.

## 1.5 Package Contents



### F - RESET Button

The RESET button provides two different reset functions, depending on how long it is pressed.

#### 1. WiFi Reset (Short Press)

Press and release the RESET button for approximately **1 second**.

This action resets the WiFi module to AP (Access Point) mode.

After about 1 minute, the WiFi network named "**CS-WIFI**" will become available again.

**Note:** After performing a WiFi reset, the Power Meter must be set up again in the CraftStrom App.

#### 2. Power Reset (Long Press)

Press and hold the RESET button for approximately **20 seconds**.

This action performs a **complete factory reset of the Power Meter**.

If the device is not responding or behaves unexpectedly, performing a power reset is recommended as the first troubleshooting step. This reset allows the device to restart without removing the main fuses.

## 1.6 Assembly

Currently, our products require a dedicated 2.4 GHz Wi-Fi network and are not compatible with dual-band networks.

Note: Many modern routers broadcast a combined 2.4 GHz and 5 GHz network under the same Wi-Fi name (SSID). If your router uses a dual-band setup, please ensure that the 2.4 GHz network is enabled and selectable separately during setup.



### Wiring the Power Meter

Please flip open the 2 covers on the power meter to expose the screws and markings!

1. Connect the **black wire** to terminal **UA**
2. Connect the **red wire** to terminal **UB**
3. Connect the **white wire** to terminal **UN**

### Installing the Current Transformer (CT) Clamps

1. Connect the **red wire** of the first CT clamp to terminal **IA\***
2. Connect the **black wire** of the same clamp to terminal **IA**
3. Connect the **red wire** of the second CT clamp to terminal **IB\***
4. Connect the **black wire** of the same clamp to terminal **IB**

### Installing Antennas

Identify the antennas:

- WiFi antenna (2.4 GHz) – antenna with two coils
- MHz antenna (433 MHz) – antenna with one coil

## 1.7 Installation – General Setup

This page describes the general installation of the Power Meter.

CT clamps and detailed wiring examples are described on the following page.

### Safety Requirements

Before starting installation, ensure that all electrical conductors are de-energized. Contact with live electrical parts is life-threatening.

- Remove the main fuses before starting any work
- Store the fuses securely to prevent accidental reconnection
- Never work on the Power Meter while voltage is present

### Installation Preconditions

Before mounting the Power Meter, verify the following:

- Approximately four fuse positions are available in the breaker box
- The installation location allows short and direct cable routes to all phases
- The bottom side of the Power Meter (including: two antenna connectors and RESET button) remains accessible after installation

If required, create an opening of approximately 30 × 10 mm in the panel cover to ensure access to these components.

### Test Fit

1. Mount the Power Meter onto the DIN rail without connecting any cables.
2. Check that all conductors reach their intended terminals without tension.
3. Remove the Power Meter from the DIN rail again before proceeding.

### Electrical Connection

1. Connect terminals 1–3 as follows:
  - Supply conductors from the main fuse or service connection to the input (top)
  - Load conductors to the output (bottom)
2. Connect the neutral conductor to terminal 4 at both the input and output.
3. Tighten all terminal screws for phase and neutral conductors securely.

### Final Mounting

1. After all eight conductors are connected, mount the Power Meter onto the DIN rail.
2. Lock the DIN rail clip on the rear of the device to ensure a secure fit.

### Power-Up

1. Reinstall the main fuses removed earlier.
2. The Power Meter will power on and begin measuring electrical parameters.
3. Continue with device registration and setup in the CraftStrom App.

## 1.7 Installation – General Setup

### Important Notice

1. After successfully installing the power meter in the app, go to the outdoor outlet that will be used for the solar kit.
2. Plug in a hairdryer and let it run for approximately 1 minute.
3. In the app, check which phase (Phase 1 or Phase 2) increases by approximately 1,500 W.
4. Note the identified phase. During inverter setup, the app will ask which phase the solar kit should be assigned to. Select the phase identified in the previous step.

**SCAN ME  
BEFORE  
YOU INSTALL**



## 1.8 Installation – Breaker Box

This page provides a visual installation example for reference only.

It illustrates the typical placement of the Power Meter, CT clamps, and antennas inside a breaker box.

**Note:** Electrical wiring of the Power Meter terminals is described on the previous pages. This page does not replace the **Power Meter - Assembly** instructions.

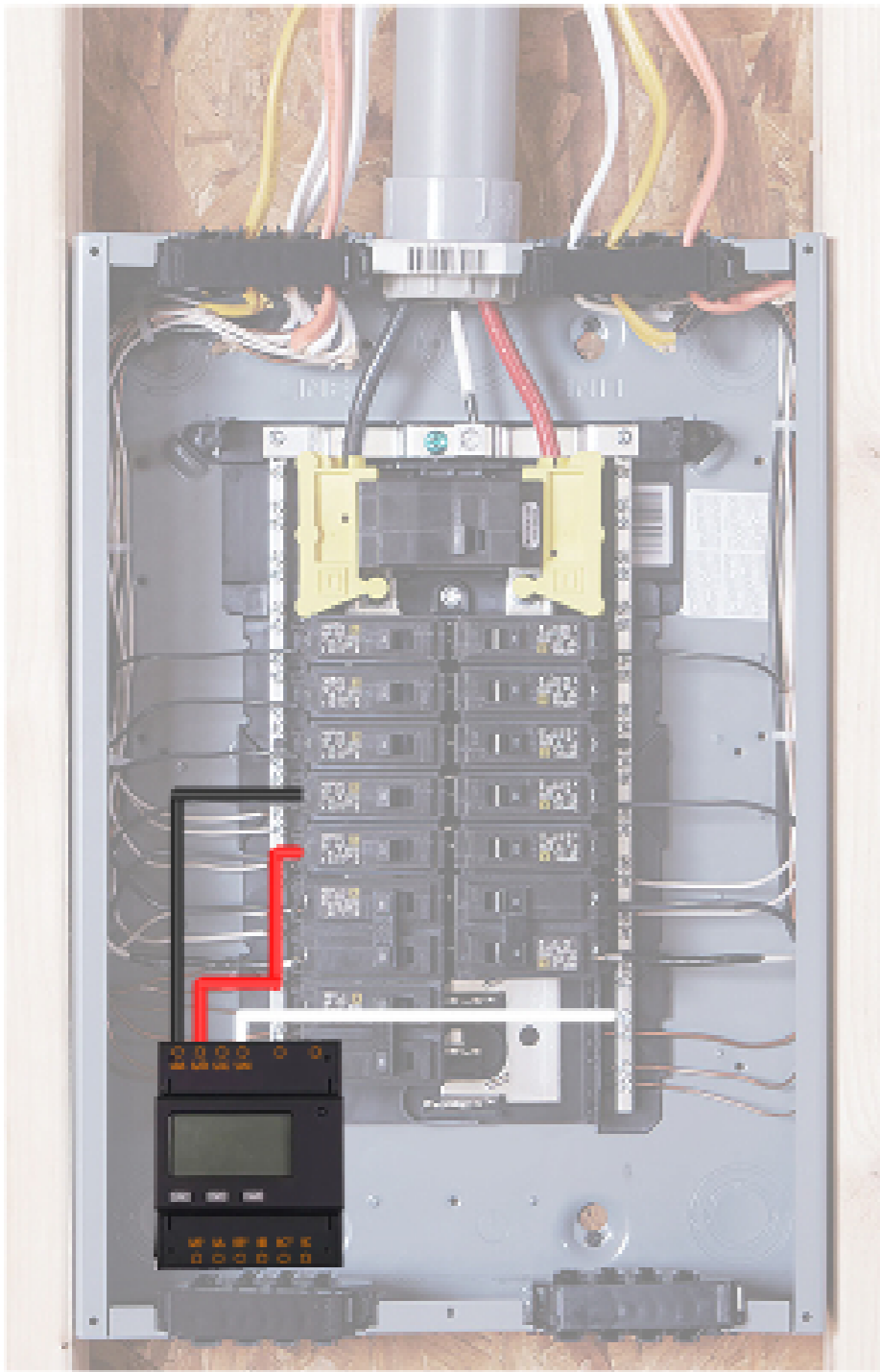

### Step 1

Mount the Power Meter inside the breaker box and connect the conductors as follows:

- L1 (black) → connect to the phase 1 breaker in panel
- L2 (red) → connect to phase 2 breaker in panel
- N (white) → connect to the neutral bar

The L1 and L2 conductors may be connected to an existing 15 A or 20 A circuit breaker, provided it complies with local electrical regulations.

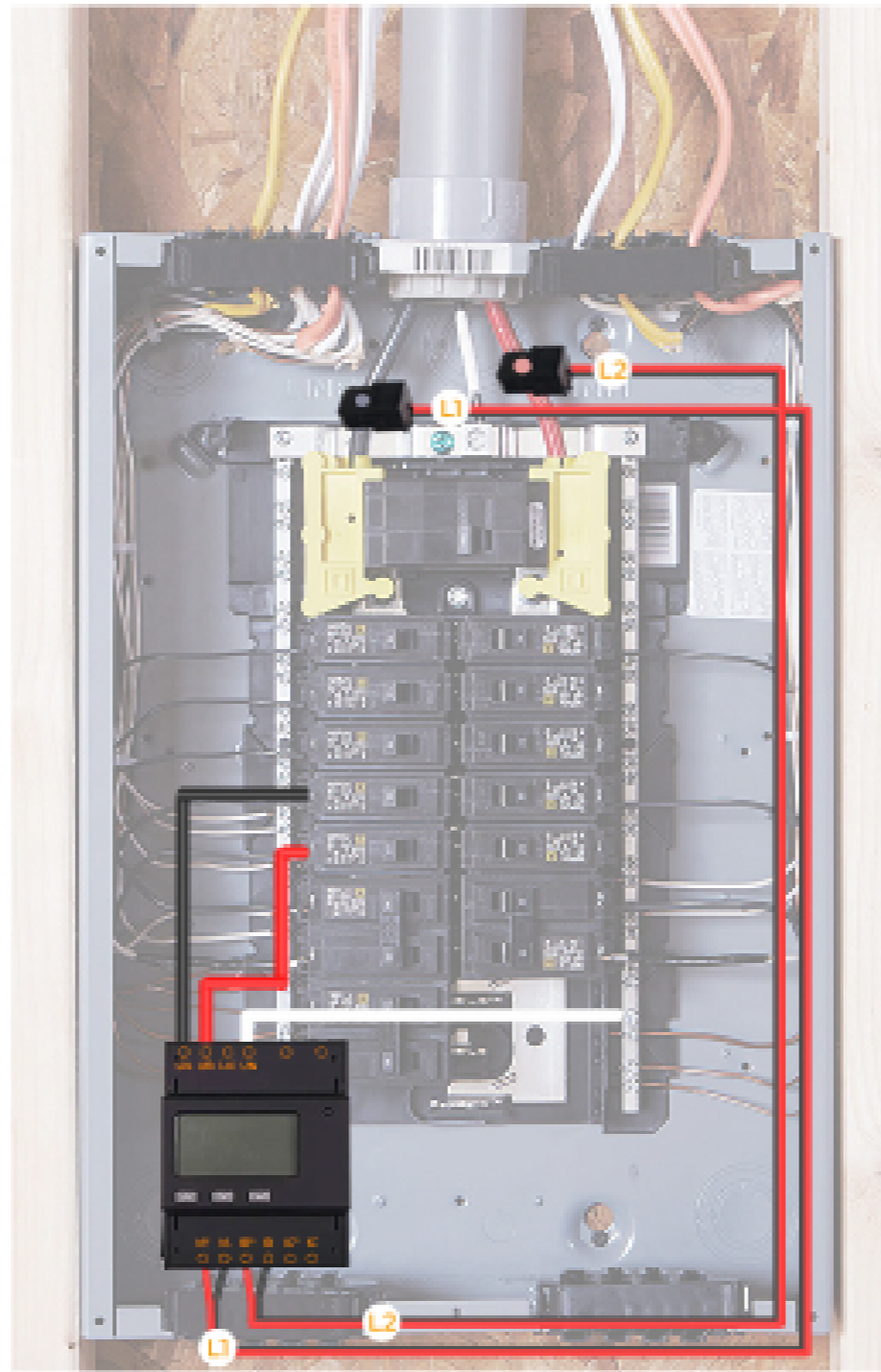

### Step 2

Install the current transformer (CT) clamps:

- Place one CT clamp around the left main supply conductor (L1)
- Place the second CT clamp around the right main supply conductor (L2)
- Ensure that each CT clamp surrounds only one conductor
- Install both clamps so that they face the same direction, as shown in the image

**Note:** Press the down button below the display to read the values for each phase. If the Power Meter displays negative values, swap the red and black CT wires coming from the clamps.

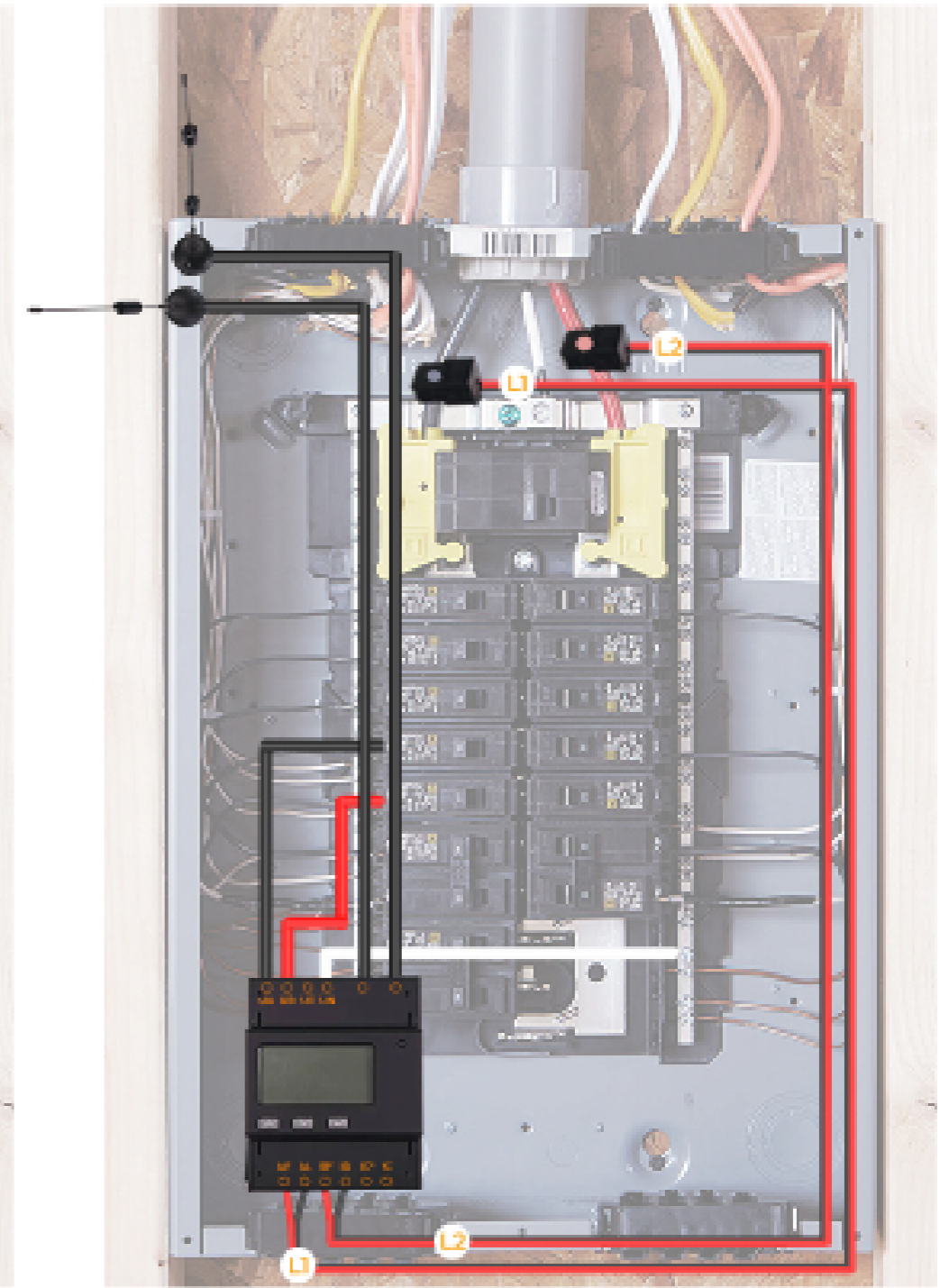

### Step 3

Place the antennas on top of the breaker box, preferably in the upper area. Use the magnetic base to attach the antennas to the metal frame of the breaker box.

#### Antenna Orientation

The **Wi-Fi antenna (2.4 GHz)**, identified by two coils, must be mounted in a **vertical (upright)** position, pointing upward.

The **MHz antenna (433 MHz)**, identified by one coil, must be mounted in a **horizontal position**.

Ensure that both antennas are securely attached and not bent, pinched, or obstructed by other components inside the breaker box.

## 1.9. Installation – CraftStrom App

The CraftStrom Power Meter operates in conjunction with CraftStrom solar inverters and energy storage systems(batteries) to manage data communication between all CraftStrom devices and the CraftStrom App.

To enable system communication and monitoring, the Power Meter must be registered in the CraftStrom App. Once all devices are successfully registered, they establish an **independent internal communication network operating at 433 MHz**.

For remote monitoring and system control, essential operating data is transmitted to the CraftStrom server via **Wi-Fi (2.4 GHz only! No dual band signals allowed)**.

**Note:** During device registration, only a dedicated 2.4 GHz Wi-Fi network may be used.

The CraftStrom App is provided free of charge and enables comprehensive monitoring and management of your solar energy system.

### Key features includes

- real-time monitoring of connected CraftStrom devices
- management of solar energy production, consumption, and battery storage
- performance tracking and system status overview

### The app also allows users to:

- review accumulated energy data in kilowatt-hours (kWh)
- compare measured values with monthly electricity bills

Energy values displayed in **kWh** correspond directly to the units shown on standard electricity invoices.



### Dashboard

Get your home energy balance overview

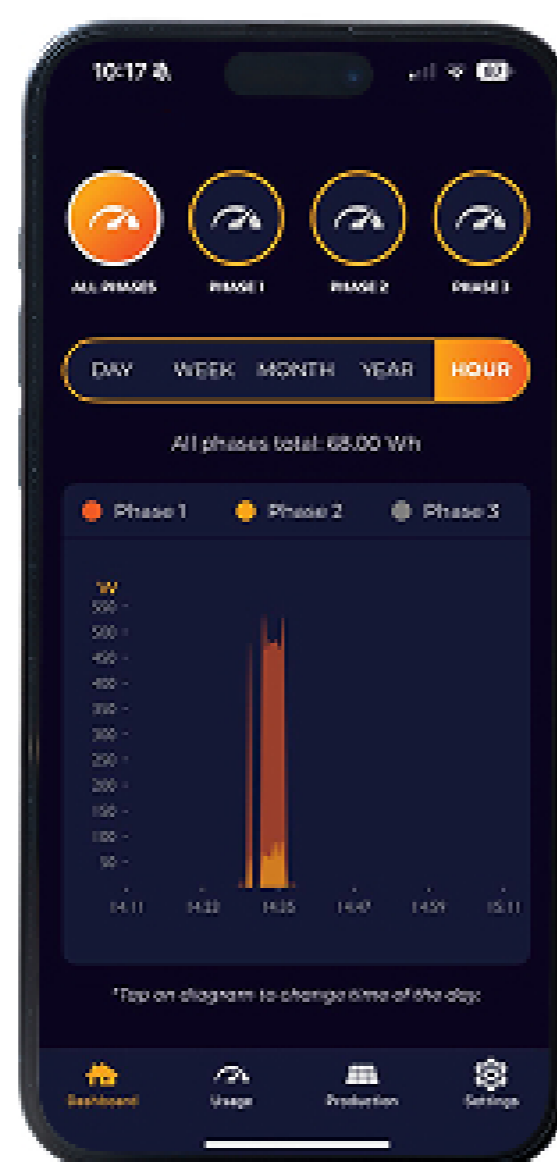

### Usage

Check power usage of your home/appliances

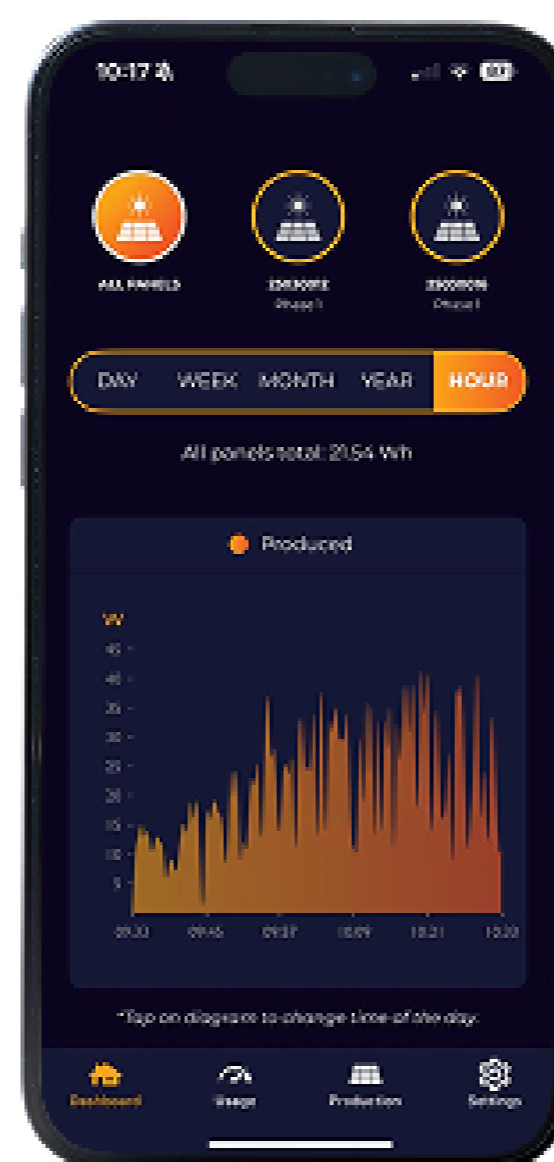

### Production

Check production of your solar kit

# 1.9 Installation – CraftStrom App

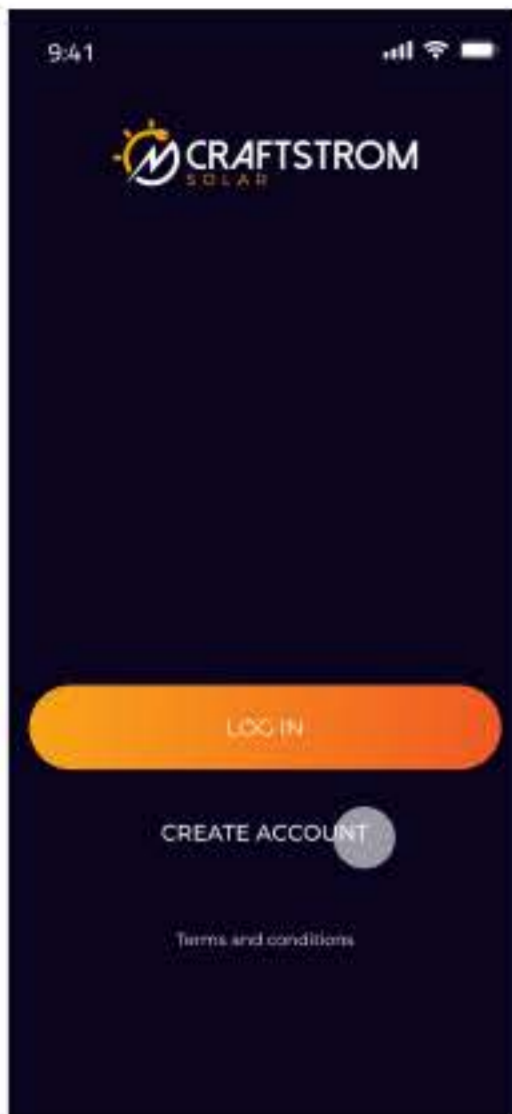

## Step 1

### Create an Account

Open the CraftStrom App and create a user account by entering a username and password.



## Step 2

### Add a New Device

In the settings menu, select Add New Device to begin the device setup process.

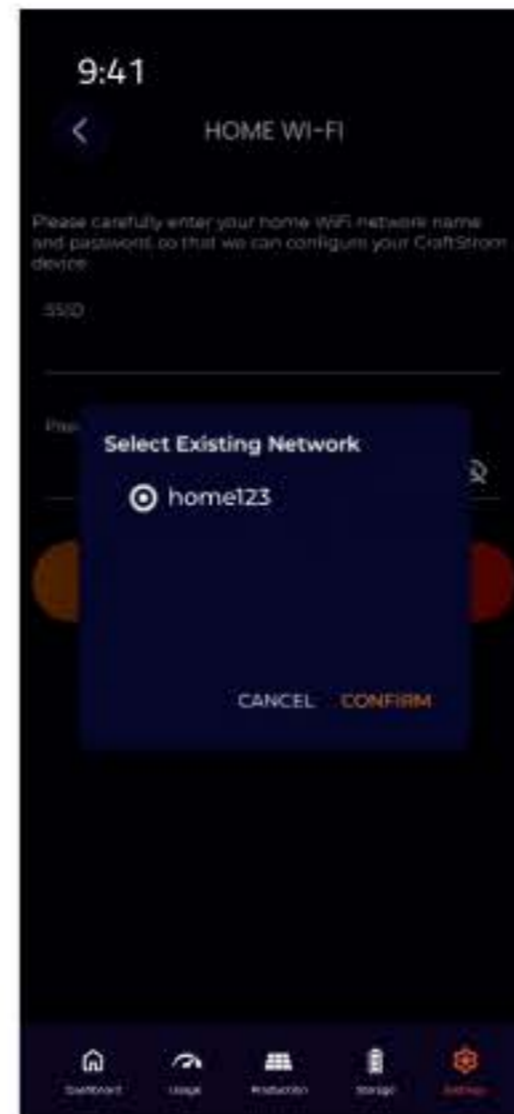

## Step 3

### Select Wi-Fi Network

Select your home Wi-Fi network (2.4 GHz) and enter the network password.



## Step 4

### Select Device Type

Choose Add Power Meter from the list of available devices.



## Step 5

### Device Identification

Scan the barcode on the Power Meter or manually enter the device ID.



## Step 6

### Confirm Device ID

Verify and confirm the entered device ID to continue.

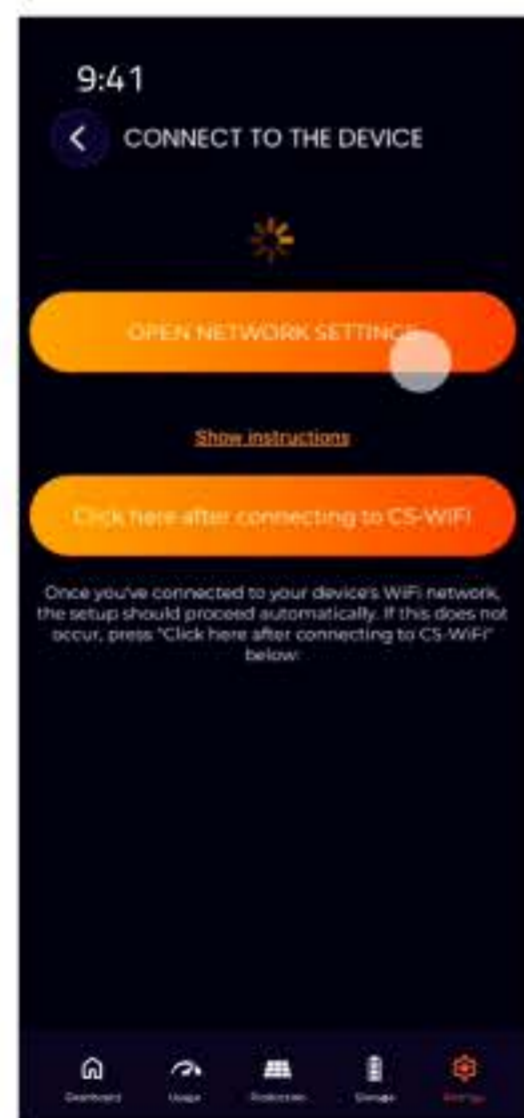

## Step 7

### Open Network Settings

Open the network settings on your mobile device using the provided button.



## Step 8

### Connect to Power Meter Wi-Fi

Select the Wi-Fi network named CS-WIFI to establish a temporary connection to the Power Meter.



## Step 9

After selecting CS-WiFi, Return to the CraftStrom App and tap the second button.

The app will then complete the setup and display the success screen. Give the App some time to populate data. We send a data-point every 30 sec.



## Step 10

Go to DASHBOARD and scroll down to communication and expand by pressing the + button next to it. Please wait until you see a green dot under WiFi communication before you start installing the next one! You can click on the dots to see ID numbers in details...

**Note:** If the Power Meter does not appear on the Usage page within 2-3 minutes, go to Settings → Devices, delete the device ID, then press and hold the RESET button next to the antenna connectors for 20 seconds. Now restart the installation process.

# 02

## SOLAR KIT

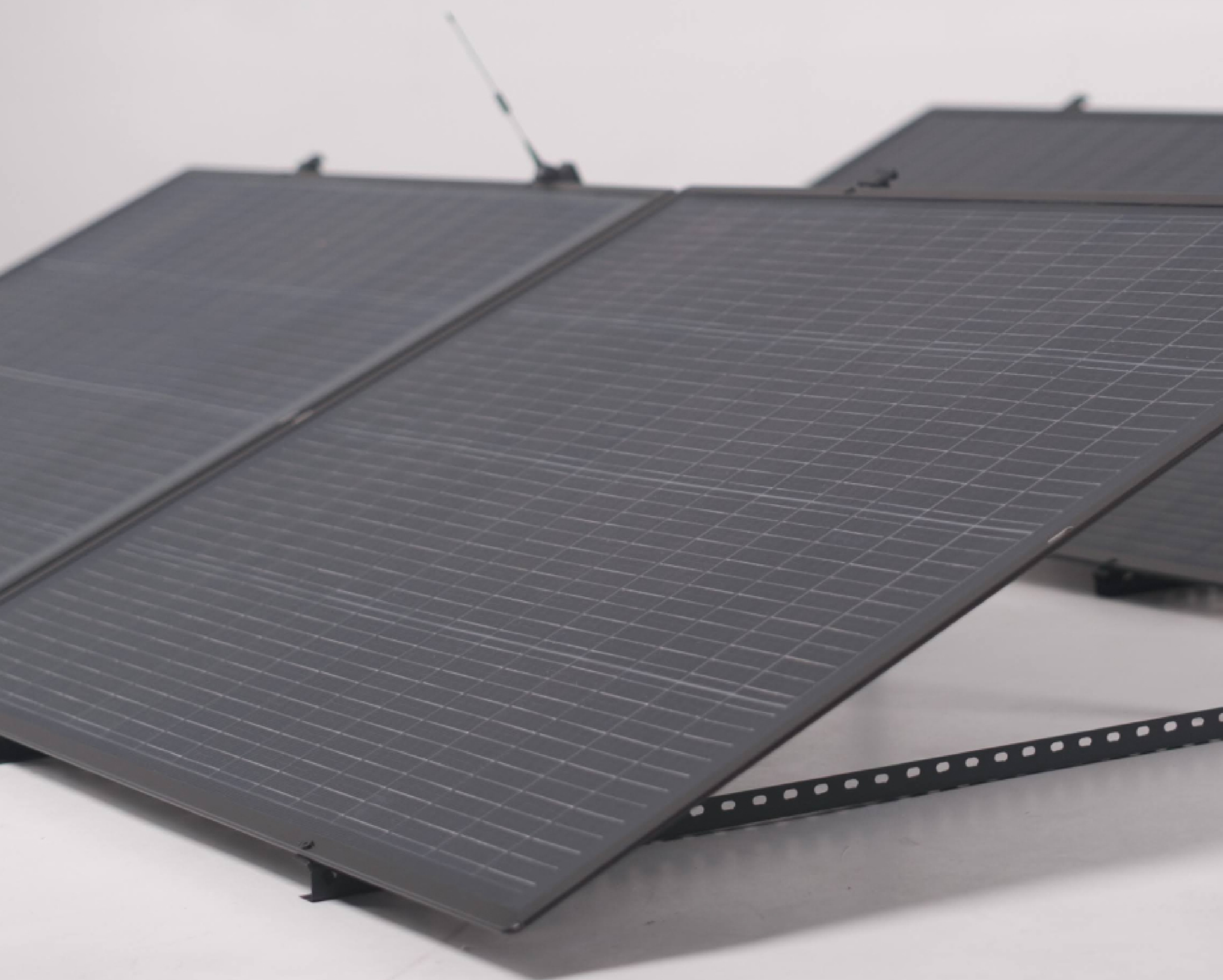

## 2.1 Safety instructions

This section describes the safe use, installation, operation, and handling of the CraftStrom HEDY microinverter.

### Caution – High Voltage & Hot Surface

- The microinverter operates with high voltages during normal operation.
- The enclosure may become hot during operation. Avoid contact with metal surfaces while the device is operating.

Do not open or remove the inverter housing. The inverter contains no user-serviceable parts. For servicing, the unit must be returned to CraftStrom.

### Warning – Electrical Safety

- The DC cable length between the solar panel and the inverter must not exceed 3 meters.
- When exposed to light, photovoltaic modules generate DC voltage, even when disconnected.
- The inverter must be connected only to a dedicated electrical circuit.
- Maximum branch circuit overcurrent protection: 20 A.

## Important Safety Instructions

HEDY microinverters are designed and tested in accordance with international safety standards. However, strict precautions must be followed during installation and operation.

- The installer must read and follow all instructions, warnings, and precautions in this manual.
- All work, including transport, installation, commissioning, and maintenance, must be carried out by qualified and trained personnel only.
- Inspect the inverter before installation for shipping or handling damage that may compromise insulation or safety clearances.
- Select the installation location carefully and ensure compliance with cooling and ventilation requirements.
- Unauthorized modification, removal of protective devices, improper use, or incorrect installation may result in serious injury, electric shock, or equipment damage.

## Grid Connection Requirements

**Before connecting the micro-inverter to the outdoor outlet, make sure you have the power meter and all inverters installed in the App! Communication needs to be up on MHZ and WIFI. You can see this in the App under Dashboard - Communication - all green dots mean you are good to go. Click on the dots to see detailed ID numbers and state!**

## Operating Restrictions

- Only two (2) × 200 W PV modules may be connected to one inverter input.
- Do not connect batteries or other power sources to the inverter.
- Do not install the inverter in flammable, explosive, corrosive, extremely hot, cold, humid, or wet environments.
- Do not operate the inverter if the Power Meter is not functioning or is disabled.

Always wear appropriate personal protective equipment (PPE), including gloves and eye

## 2.1 Safety instructions

### Abnormal Operation

If any abnormal behavior is observed during operation, stop using the device immediately and contact CraftStrom support.

### Residual Electrical Hazard

#### Warning

Even when disconnected from the public grid, certain components inside the microinverter may retain residual electrical charge.

- Always exercise extreme caution when handling the inverter after disconnection.
- Before touching any part of the inverter, ensure that:
  - the surface temperature is safe to touch
  - voltage levels have dropped to a safe potential

### Liability Disclaimer

CraftStrom assumes no responsibility for damage or injury caused by:

- improper installation
- incorrect operation
- non-compliance with this manual
- unauthorized modification of the product

Liability for commercial third-party components rests with their respective manufacturers.

### Qualified Personnel Requirement

All electrical installation, servicing, and maintenance work must be performed by a licensed electrician and in full compliance with local electrical regulations and standards.

Failure to comply with these requirements may result in serious safety hazards and void the product warranty.

## 2.2 Product overview

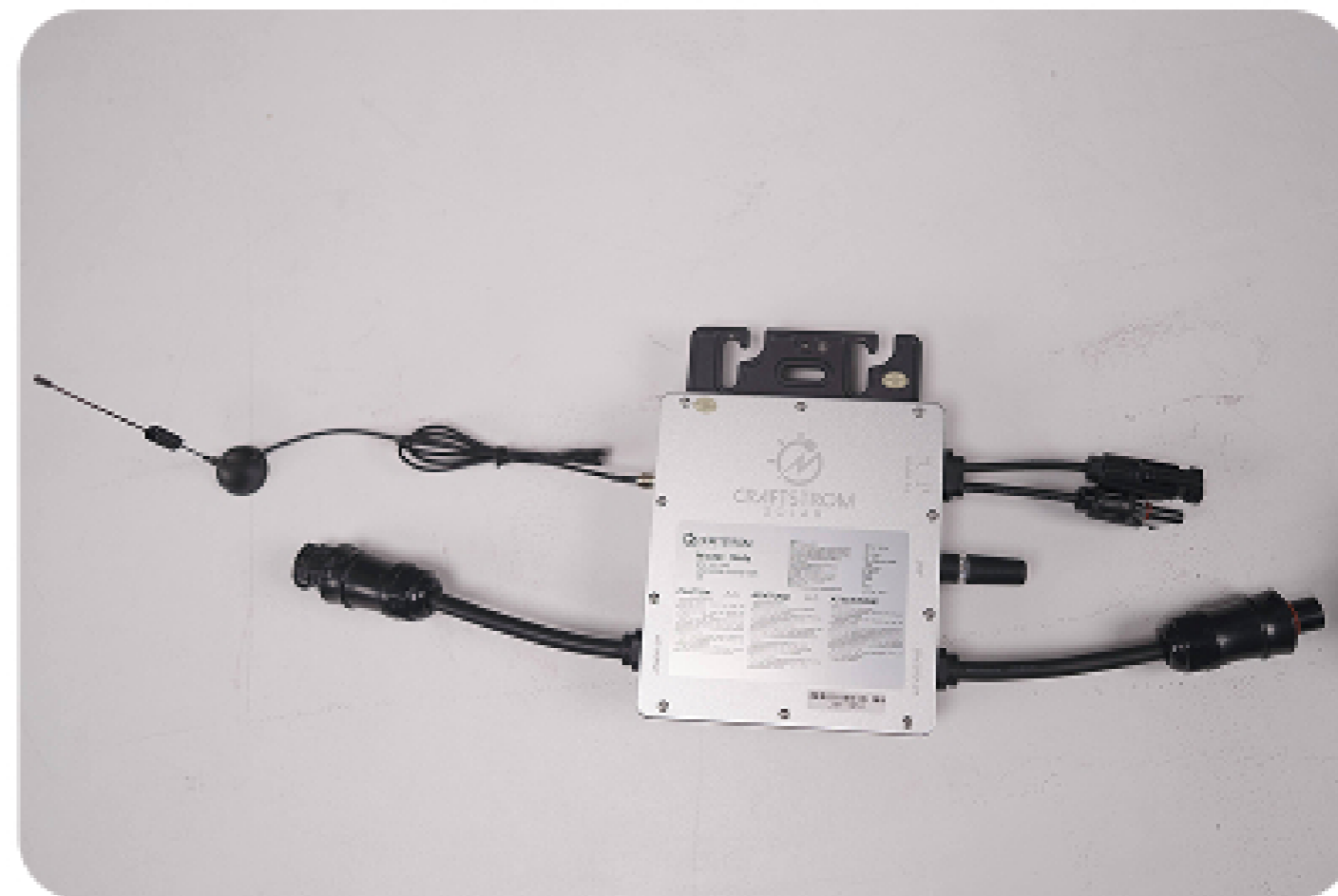

### Solar Kit & Inverter

The CraftStrom Solar Kit is a plug-in photovoltaic system designed to generate electrical energy from sunlight for residential use. The system is intended for easy integration into existing electrical installations and operates in combination with other CraftStrom components.

The Solar Kit consists of solar panels, a micro-inverter, and a power meter that work together to convert solar energy into grid-compatible AC power for household consumption.

### System Function

Solar energy is generated by the photovoltaic panels in the form of direct current (DC).

The inverter converts this DC power into alternating current (AC) synchronized with the public electricity grid.

The generated energy is supplied directly to household loads, helping to reduce grid consumption and overall electricity costs. Depending on system configuration and grid regulations, surplus energy may be exported to the grid.

### Role of the Inverter

The inverter is the central functional component of the Solar Kit.

Its primary functions include:

- converting DC power from the solar panels into usable AC power
- synchronizing the system with the electrical grid
- ensuring safe and stable system operation

The inverter enables efficient energy conversion while maintaining compliance with grid connection requirements.

## 2.2 Product overview

### System Integration

When used together with the CraftStrom Power Meter, the Solar Kit allows accurate monitoring of:

- solar energy production
- household energy consumption
- power flow direction

All system data is visualized in the CraftStrom App, providing real-time insight into system performance and energy usage.

### Modular System Design

**The CraftStrom Solar Kit is designed as a modular and scaleable system.**

**It can be expanded with additional solar panels or combined with other CraftStrom components to adapt to changing energy requirements.**

**This modular architecture allows flexible system configuration. You can install up to 2000W on one circuit and you can install another kit on the other phase of your breaker box. We measure each phase in your breaker box so we can balance each one individually. You can install multiple kits on multiple phases.**

## 2.3 Technical Specifications – Solar Panels

### Semi-Flexible & Transparent Bifacial Solar Panels (36V)

Parameter	Value
Max Power Front	200 W
Max Power Back	70 W
Max Power Voltage	36.48 V
Open-circuit Voltage	42.88 V
Max Power Current	5.49 A
Cell Efficiency	23.5 %
Protective Layer	ETFE
Max System Voltage	DC 1000 V
Dimensions	1170 × 923 × 3.8 mm
Weight	4.2 kg
Working Temperature	-40 °C to +80 °C

### Semi-Flexible & Transparent Bifacial Solar Panels (24V)

Parameter	Value
Max Power Front	200 W
Max Power Back	70 W
Max Power Voltage	23.2 V
Open-circuit Voltage	27.7 V
Max Power Current	8.63 A
Cell Efficiency	23.5 %
Protective Layer	ETFE
Max System Voltage	DC 1000 V
Dimensions	1170 × 923 × 3.8 mm
Weight	4.2 kg
Working Temperature	-40 °C to +80 °C

## Warning

This module produces electricity when exposed to light.

Follow all applicable electrical safety precautions.

- ONLY qualified personnel should install or perform maintenance work on these modules.
- Be aware of dangerous high DC voltage when connecting modules.
- DO NOT damage or scratch the rear surface of the module.
- FOLLOW the battery manufacturer's recommendations if batteries are used with modules.

## 2.4 Technical Specifications – Inverter

### Input & Operating Parameters

Parameter	Value
Maximum input power	400 Watt
Output voltage mode	120 / 230 V auto switch
PV open circuit voltage	60–100 VOC
Operating voltage range	55–100 V
MPPT range DC	65–100 V
Short circuit current	7 A
Maximum working current	6.3 A

### Output Parameters

Parameter	@120V	@230V	@240V
Output peak power	400 Watt	300 Watt	350 Watt
Rated output power	400 Watt	300 Watt	350 Watt
Output current	2.91 A	1.44 A	1.52 A
AC voltage range	80–160 VAC	180–280 VAC	180–280 VAC
AC frequency range	48–51 Hz / 58–61 Hz	48–51 Hz / 58–61 Hz	48–51 Hz / 58–61 Hz
Power factor	>95%	>95%	>95%
Number of branch connections	30 pcs (single)	30 pcs (single)	30 pcs (single)
Output efficiency	99%	99.5%	99.5%
Static MPPT efficiency	99.5%	99.5%	99.5%
Max output efficiency	99.5%	99.5%	99%
Loss of power at night	<0.5 W	<0.5 W	<0.5 W
Total current harmonics	5%	5%	5%

## 2.4 Technical Specifications – Inverter

### General Characteristics

Parameter	Value
Apparent and technical features	—
Temperature range	-20 °C to +50 °C
Dimensions (L × W × H)	165 mm × 176 mm × 38 mm
Net weight	0.82 kg
Enclosure rating	NEMA 3R
Heat dissipation mode	Self-cooling
Communication mode	WiFi
Power transmission mode	Reverse transmission, Load priority
Monitoring system	Mobile phone App, Browser
Electromagnetic compatibility	EN 50081 Part 1, EN 50082 Part 2, CISPR 22, EN 61000
Power grid	EN 61000-3-2, EN 62109, UL STD 1741
Power grid detection	DIN VDE 4105, IEEE STD 1547.1, IEC 61727
Certification	FCC, CE, ETL

### Packing Information

Parameter	Each (Packaging)	Box (15 pcs)
Weight	1.28 kg	19.2 kg
Size	245 × 202 × 60 mm	450 × 395 × 345 mm

## 2.5 Package Contents

The CraftStrom Solar panel kit package contains:

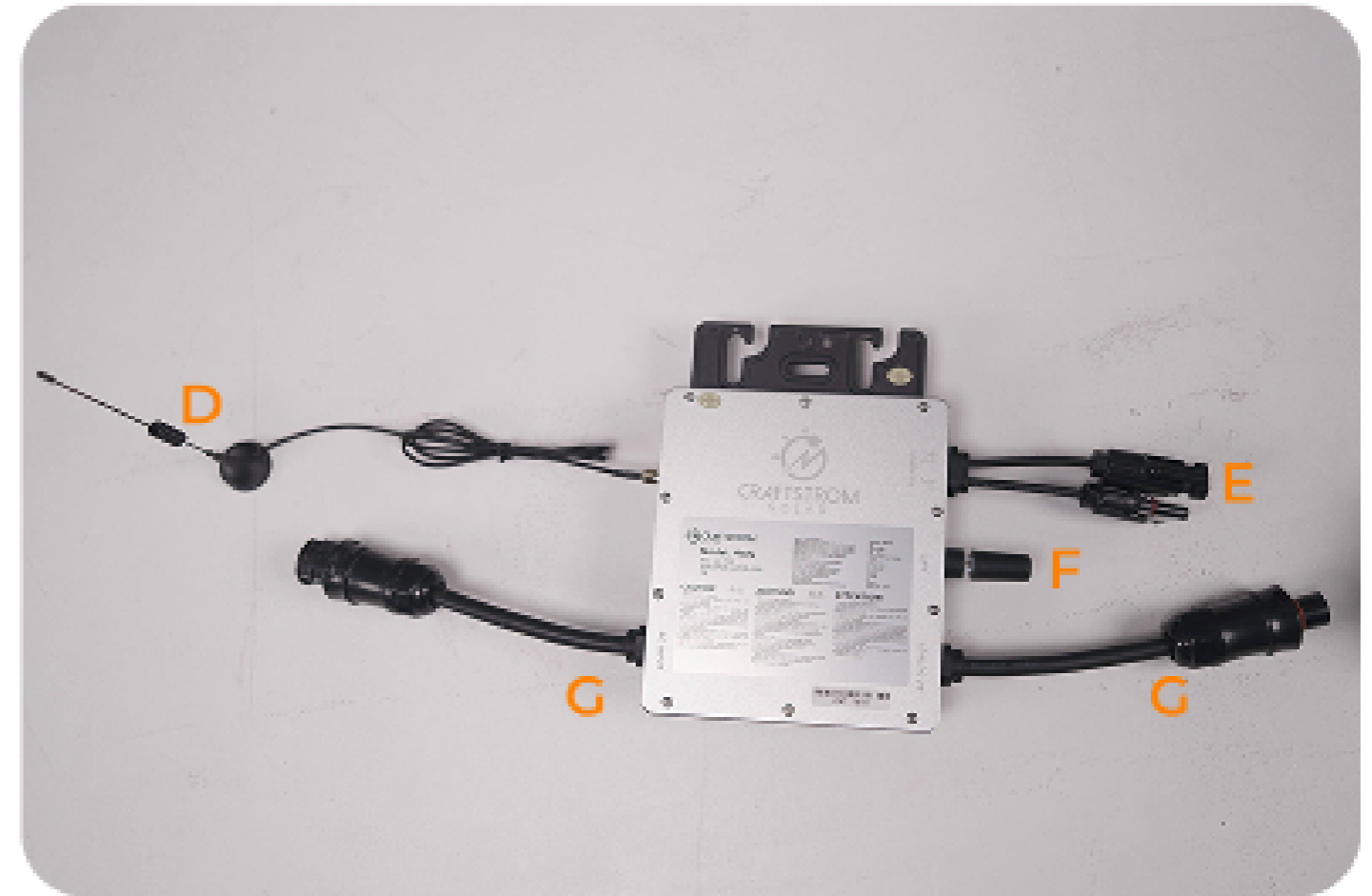

### A - Solar Panel

- Bifacial semi-flexible solar panels
- Designed for outdoor use on curved or flat surfaces
- Lightweight construction with ETFE protective layer
- Equipped with MC4 connectors for quick and secure connection

### B - Smart Inverter

- Converts DC power generated by the solar panels into AC power
- Plug-and-play design for direct connection to outdoor power outlets
- Integrated WiFi communication for monitoring via the CraftStrom App
- Designed for outdoor installation

### C - Inverter Connector Cables

- Used for parallel connection of multiple micro inverters (max. 5 units).

### D - MHz Antenna (433 MHz) – 1 pc

- Enables sub-GHz communication between CraftStrom devices
- Used for internal system communication
- Magnetic base for internal mounting

### E - MC4 Connector

- Used to connect the solar panels to the micro inverter.

### F - WiFi Antena

- Provides wireless communication between the inverter and the home WiFi network.
- Required for system setup and monitoring in the CraftStrom App.

### G - AC port

- AC output port is used to connect the inverter to the AC power cable or to a connector cable when installing multiple systems.

## 2.5 Package Contents

The CraftStrom Solar panel kit package contains:

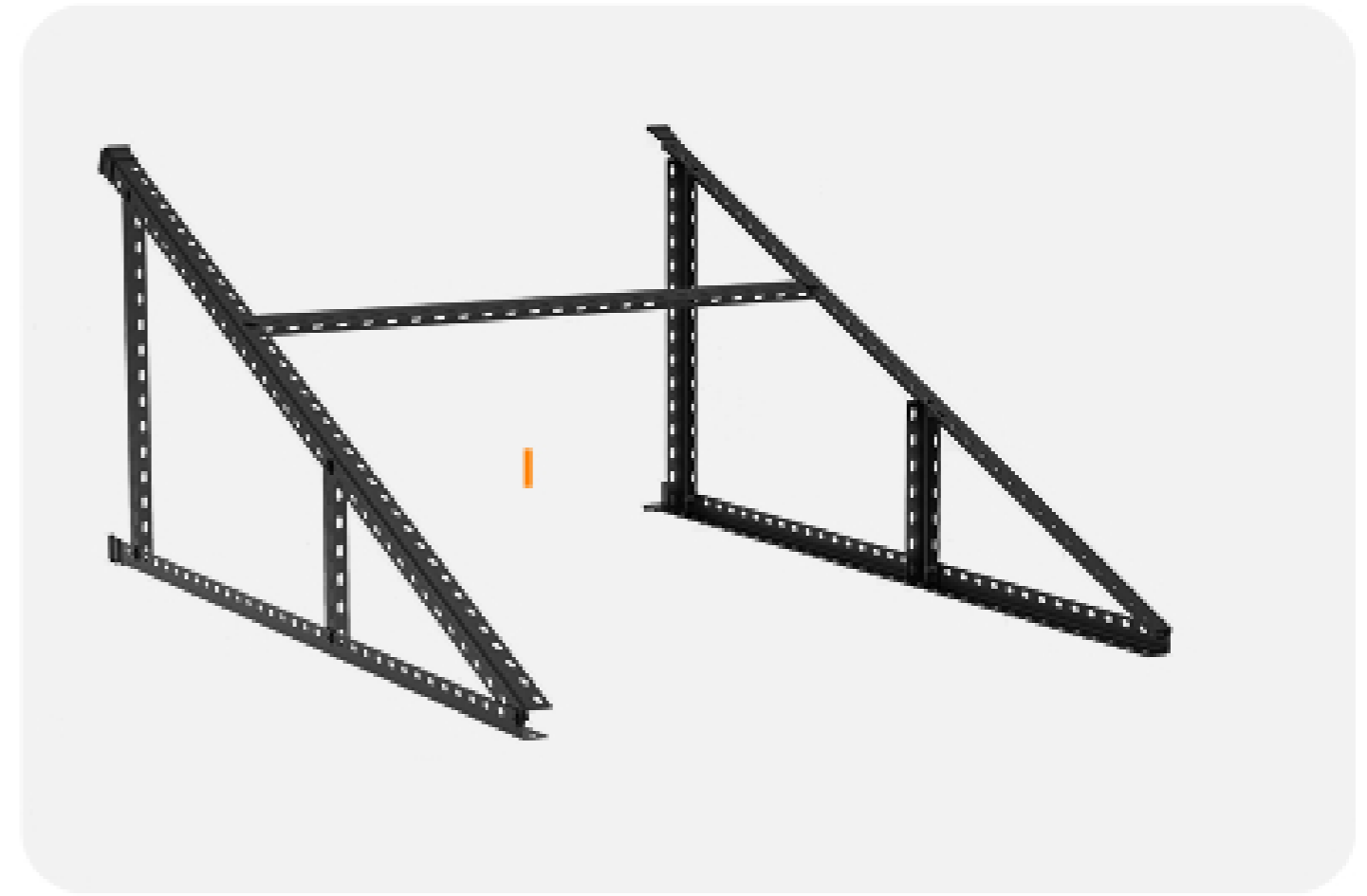

### H - AC Cable

- Used to connect the micro inverter to a standard outdoor power outlet
- Pre-assembled and ready for use
- Designed for outdoor environments

### I - Solar Panel Stand

- Lightweight flexible solar panel mount
- Designed for 200W panels
- Holds micro-inverters
- Ground-or Railing-mount, Flexes for heavy winds

## 2.6 Installation – General Setup

This page describes the general installation of the Solar Kit. Detailed mounting options, including installation on a stand, are described on the following pages.

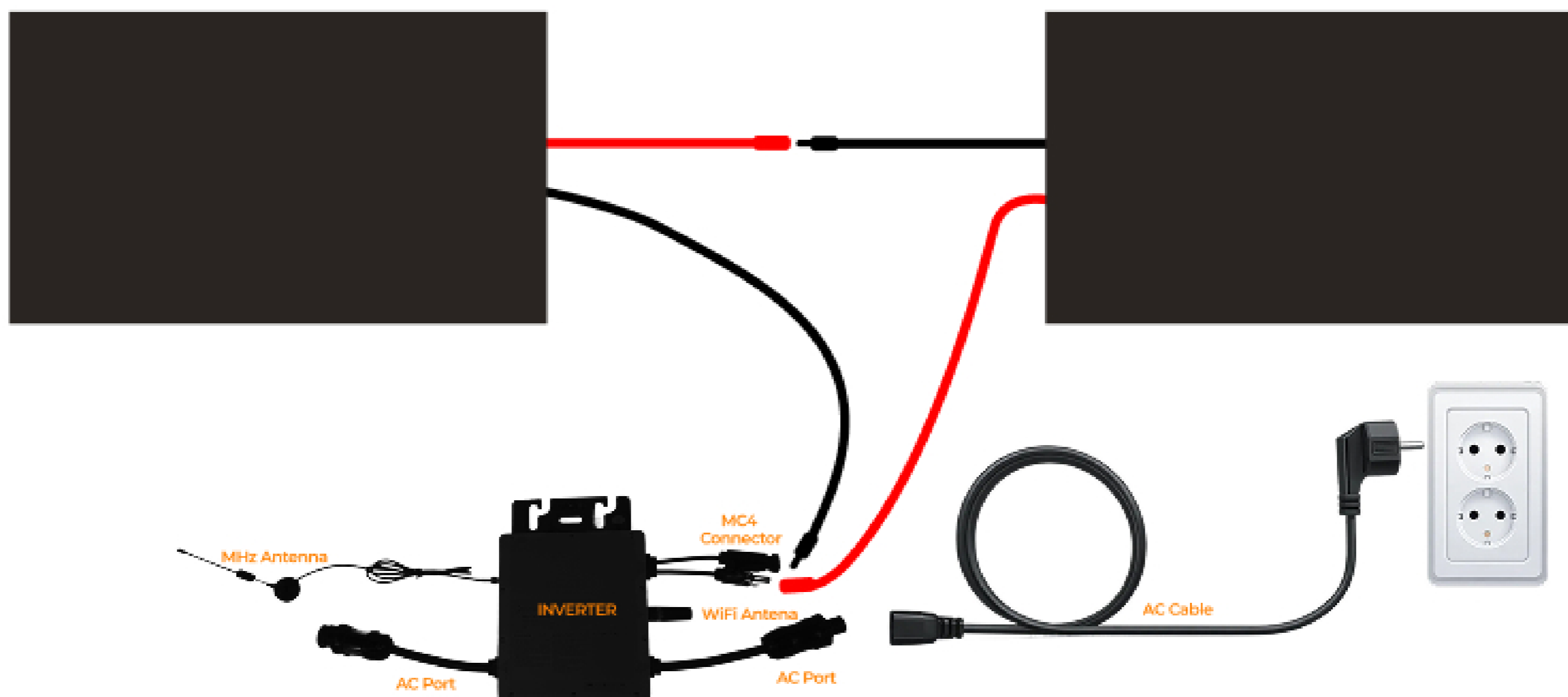

### Step 1 – Unpack Components

Carefully unpack the solar panels. Avoid stepping on or striking the panel, as excessive pressure may result in permanent damage.

### Step 2 – Prepare the Micro Inverter

Unpack the micro inverter and attach the included antennas:

- **WiFi antenna (2.4 GHz)**
- **MHz antenna (433 MHz)**

Ensure both antennas are securely connected before installation.

### Step 3 – Connect Solar Panels to the Mounting system

**Connect the solar panels** and to the mounting system with the provided hardware. **Make sure the panels are oriented in a way that the 2 junction boxes with cables are facing each other when mounting the pair. you want to bundle the cables neatly and run the to the inverter.**

- If in stalled on a balcony then please use Loctite (glue for threading) to secure the hardware.

### Step 4 – How to mount the Micro Inverter

**Install the micro inverter in a shaded and dry location. Connect the leads form the panels as seen in the illustration above. +&- from opposite panels and the other 2 cables power up the inverter. The inverter AC cable should not be installed yet! Thats the last step**

- Ensure sufficient airflow around the inverter
- The inverter housing acts as a heat sink and may become hot during operation

## 2.6 Installation – General Setup

### Step 6 – App Installation and Pairing

Install the inverter in the CraftStrom App (**2.9. Installation – CraftStrom App**) - **one inverter at a time**.

This prevents WiFi interference during setup.

- Complete setup for the first inverter
- Repeat the process for additional inverters if installed

**Before connecting the micro-inverter to the outdoor outlet, make sure you have the power meter and all inverters installed in the App! Communication needs to be up on MHZ and WIFI. You can see this in the App under Dashboard - Communication - all green dots means you are good to go. Click on the dots to see detailed ID numbers and state!**

### Step 5 – Connect AC Power

Connect the **AC cable to the inverter** and **plug it into a standard outdoor power outlet**.

- Do not use the outdoor outlet to power other devices
- **Use only one inverter at a time during initial setup**

### Step 7 – Final Check

Verify that:

- All panel connections are secure
- The inverter is properly mounted
- Antennas are correctly positioned
- The system is visible and reporting correctly in the app

### Step 8 – Maintenance

- During snowfall, **remove heavy snow loads from the solar panels**.
- **Clean the panels regularly using mild soap and water** to remove dirt from the ETFE surface.
- **Do not use brushes or abrasive tools**, as they may scratch the ETFE layer.
- Regularly inspect all cable connections for cracks, wear, or animal damage to prevent short circuits.

#### Attention

- Even a small area of distortion on a solar panel can cause damage to internal cells.
- **Avoid stepping on or striking the panel, as excessive pressure may result in permanent damage.**
- **Ensure the solar panel is securely mounted and not left freely supported**, as shown in the example.
- Proper rear stabilization is required to prevent damage caused by strong crosswinds.
- It is recommended to use 3M Very High Bond (VHB) double-sided tape as an additional method to secure the panels.

## 2.7 Installation – Multiple Panels (System Expansion)

- *Do not connect multiple systems before completing the app installation for each system.*
- *Install and set up one system (2 solar panels + 1 inverter) at a time*
- *Wait until the inverter appears and reports data correctly in the app before adding the next*
- *Repeat the installation steps for each additional system*

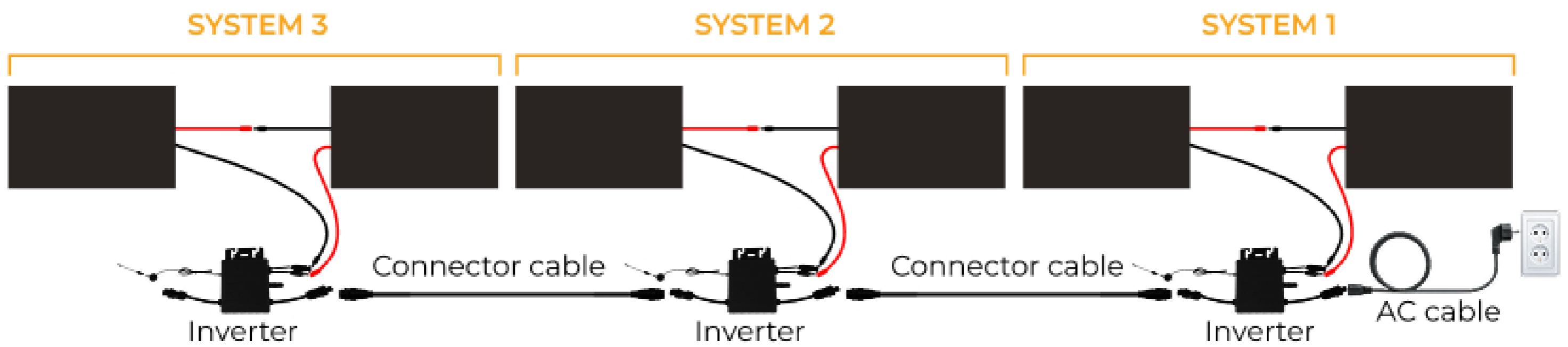

**Note:** To expand the initial system (**system 1**) with an additional (**system 2/3**), repeat Steps 1–4 of **Section 2.6 – General Setup** for each additional panel set. After completing Step 4, continue with the step below:

**After installing an additional system, connect one end of the connector cable to the AC port of the one inverter and the other end to the AC port of another inverter that you already plugged into outlet.**

Each additional inverter is connected in parallel to the previous one.

Continue adding systems in the same way until the installation is complete.

**The final inverter in the chain is then connected to the outdoor power outlet using the AC cable.**

**Note:** A maximum of 5 inverters can be connected in parallel.

## 2.8 Installation – Stand



### Step 1

Use 5×8 pcs of M5 bolts (with matching nuts/washers) to assemble the two long support rails into the initial V-shape base.

- Lay the two perforated rails on a flat surface.
- Align the holes at one end and fasten them together to form the angle shown.
- Keep the bolts snug but not fully tightened yet, so you can adjust alignment in the next steps.

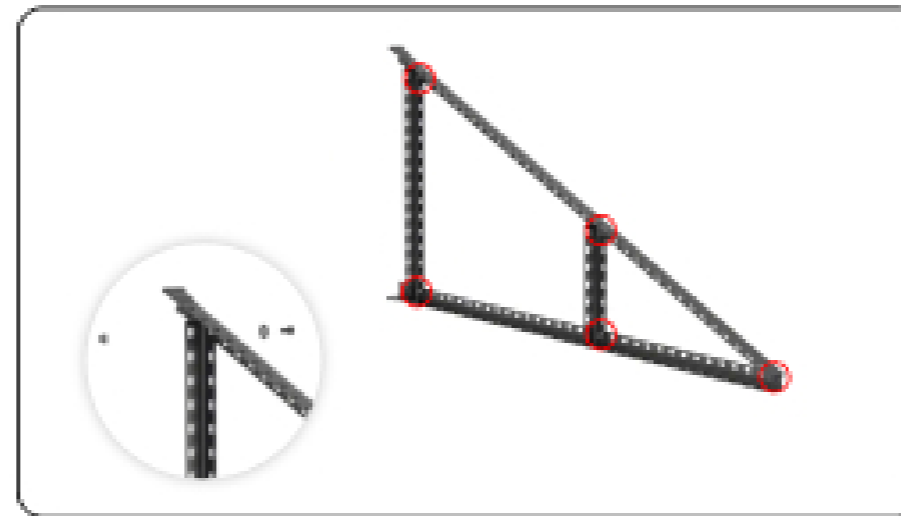

### Step 2

Add the two vertical support rails to the base assembly.

At the marked connection points, fasten the supports using the same bolts and method as in Step 1.

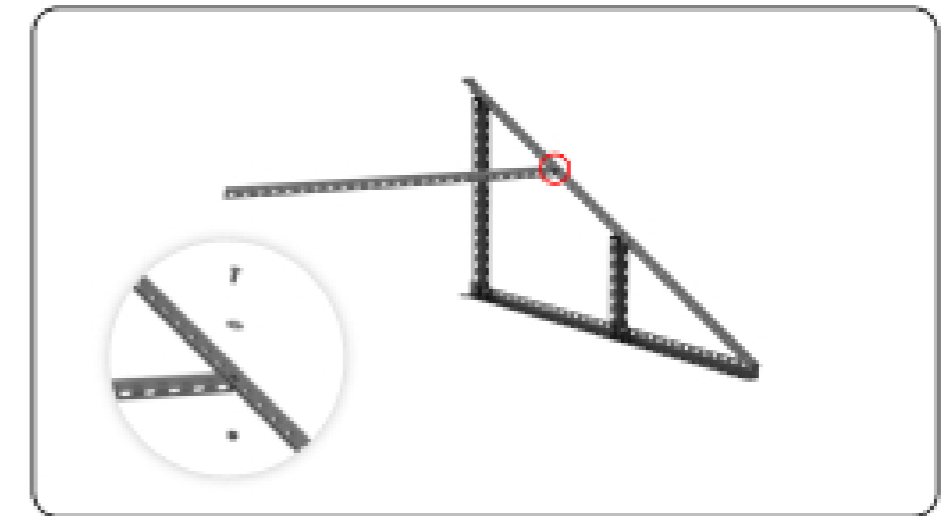

### Step 3

Attach the horizontal support rail to the vertical support at the marked connection point.

Secure it using the same bolts and fastening method as in Steps 1 and 2.

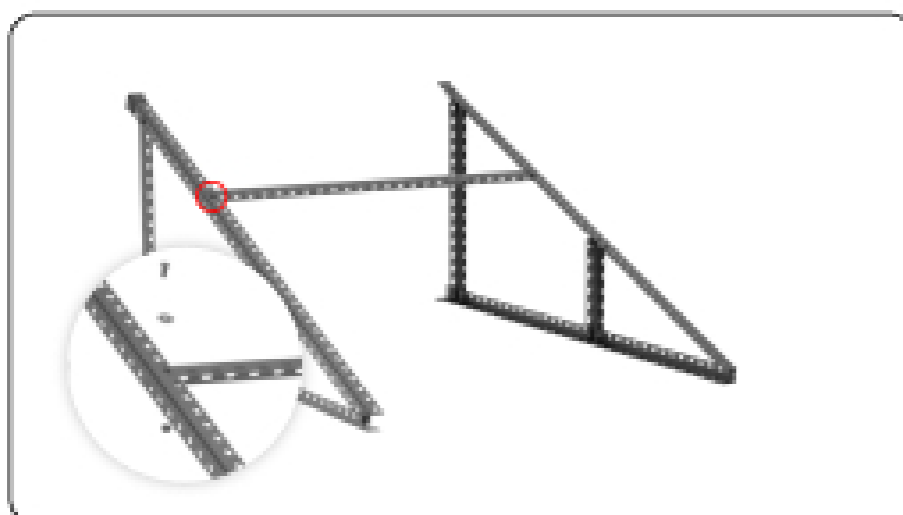

### Step 4

Attach the second side frame to the horizontal support rail. Fasten it at the marked connection point using the same bolts and method as in the previous steps.

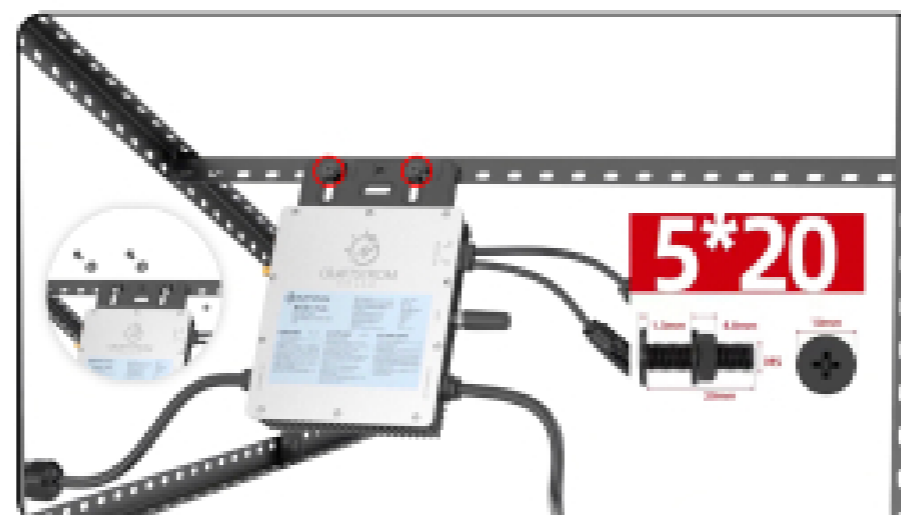

### Step 5

Secure the micro inverter to the stand using 5×20 mm bolts at the marked mounting points. Ensure the inverter is firmly attached and positioned to allow proper airflow.

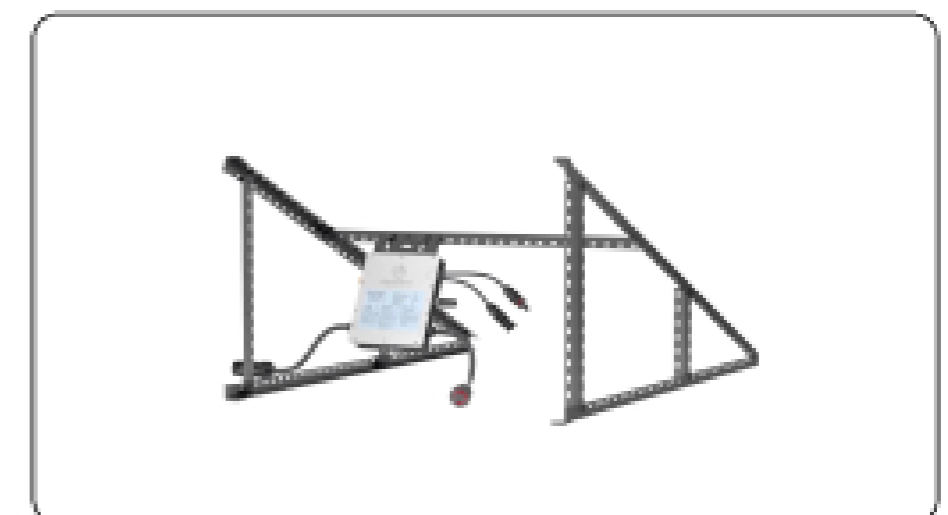

### Step 6

At this stage, the stand should be fully assembled with the micro inverter mounted. Verify that the structure matches the illustration and is ready before installing the solar panel.

## 2.8 Installation – Stand

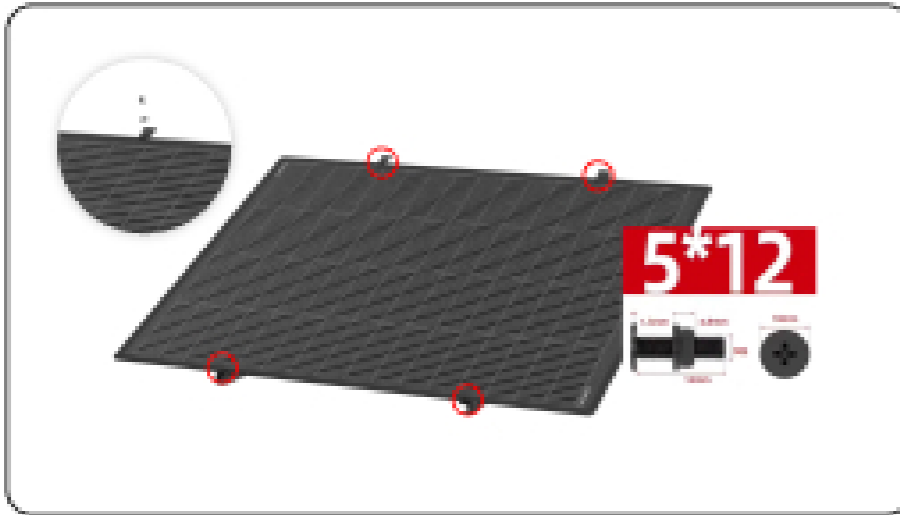

### Step 7

Place the solar panel onto the stand and align the mounting eyelets with the stand mounting holes.

Secure the panel using 5×12 mm bolts at the marked positions.

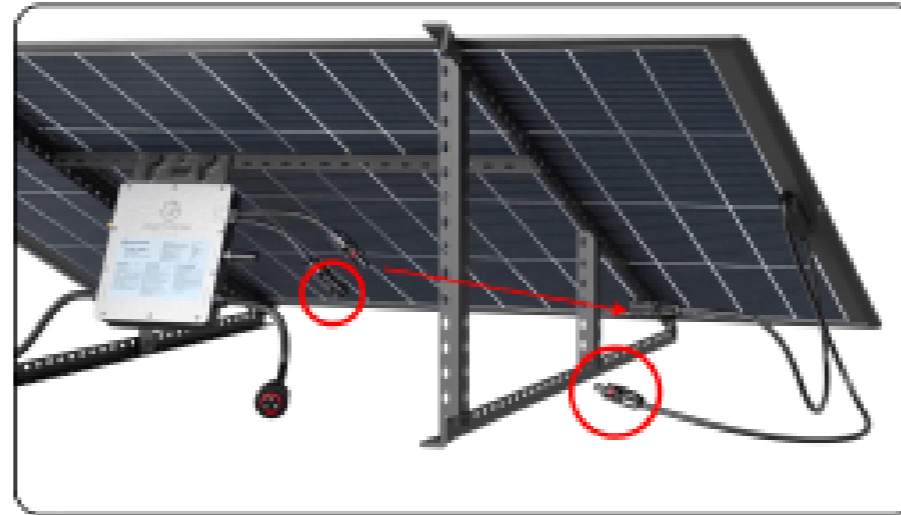

### Step 8

Connect the positive (+) lead from one solar panel to the negative (-) lead of the second panel. The two remaining leads should then be connected to the inverter. Ensure all connectors are fully inserted and securely locked into place. The connectors are keyed and will only fit together in the correct orientation. Do not force the connections.

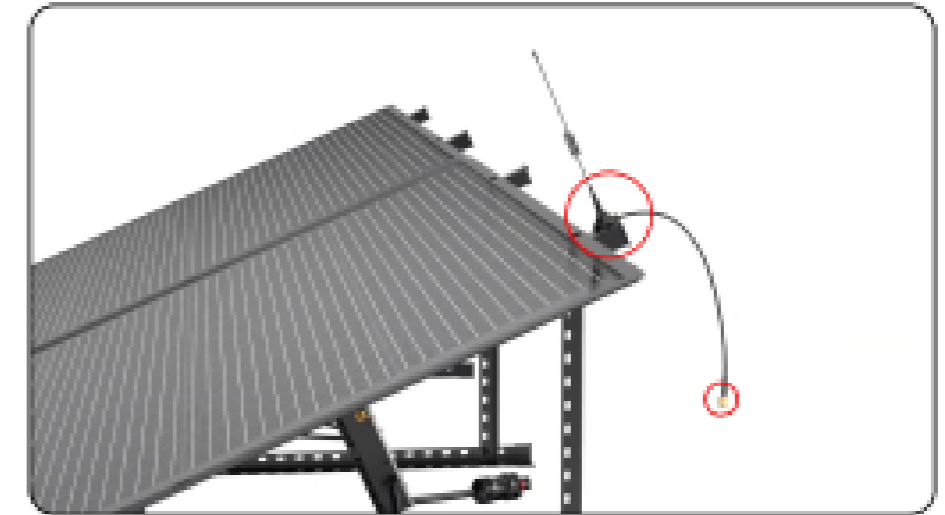

### Step 9

Attach the MHz Antenna to the micro inverter and route the antenna cable as shown. Ensure the antenna is positioned securely and not under tension or obstructed.



### Step 10

Connect the other end of the antenna installed in Step 9 to the marked antenna port on the micro inverter.

Ensure the connector is fully seated and securely tightened.

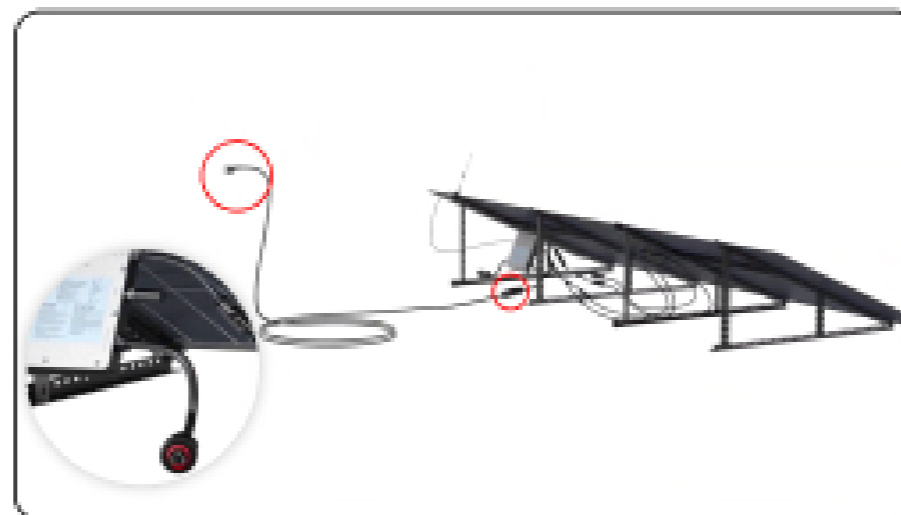

### Step 11

**Do not connect the AC cable to the outdoor outlet at this stage.**

**Install and configure each inverter individually in the App.**

**To power on an inverter for setup, connect only the solar panel input to the inverter. Complete the setup process for one inverter before proceeding to the next inverter.**

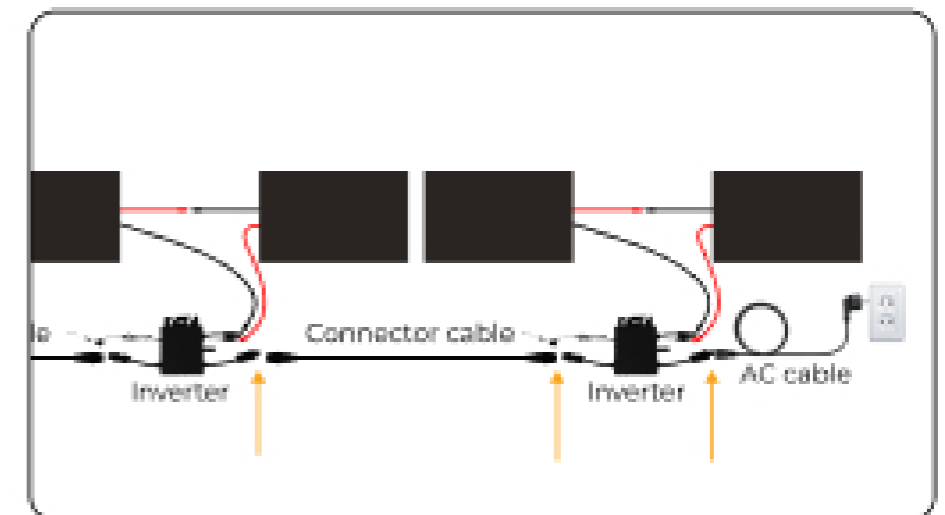

### Step 12

#### Adding Additional Panels

If you want to add more solar inverters and panels, do not connect the DC cables from the panels to the inverters.

**Note: A maximum of 5 inverters can be connected in parallel. Install and set up one complete system (2 solar panels + 1 inverter) at a time, wait until it appears and reports data correctly in the app, and only then proceed with connecting and installing the next system.**

## 2.9 Installation – CraftStrom App

The CraftStrom Inverter operates in conjunction with CraftStrom power meter and energy storage systems (batteries) to manage data communication between all CraftStrom devices and the CraftStrom App.

To enable system communication and monitoring, the Inverter must be registered in the CraftStrom App. Once all devices are successfully registered, they establish an **independent internal communication network operating at 433 MHz**.

For remote monitoring and system control, essential operating data is transmitted to the CraftStrom server via **Wi-Fi (2.4 GHz)**.

**Note:** During device registration, only a dedicated 2.4 GHz Wi-Fi network may be used.

The CraftStrom App is provided free of charge and enables comprehensive monitoring and management of your solar energy system.

### Key features include

- real-time monitoring of connected CraftStrom devices
- management of solar energy production, consumption, and battery storage
- performance tracking and system status overview

### The app also allows users to:

- review accumulated energy data in kilowatt-hours (kWh)
- compare measured values with monthly electricity bills

Energy values displayed in **kWh** correspond directly to the units shown on standard electricity invoices.

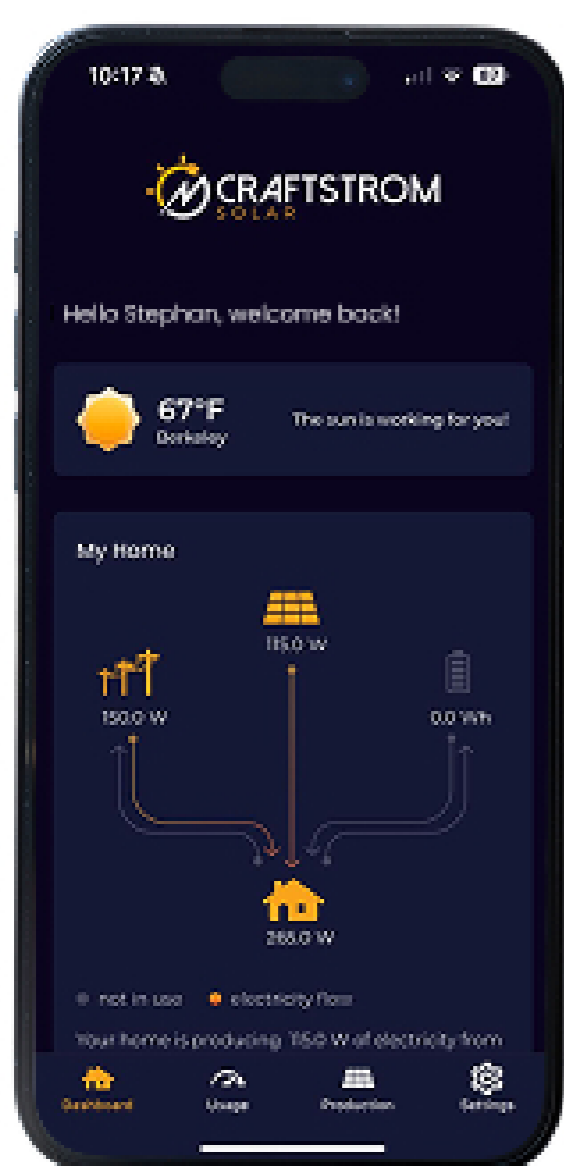

### Dashboard

Get your home energy balance overview

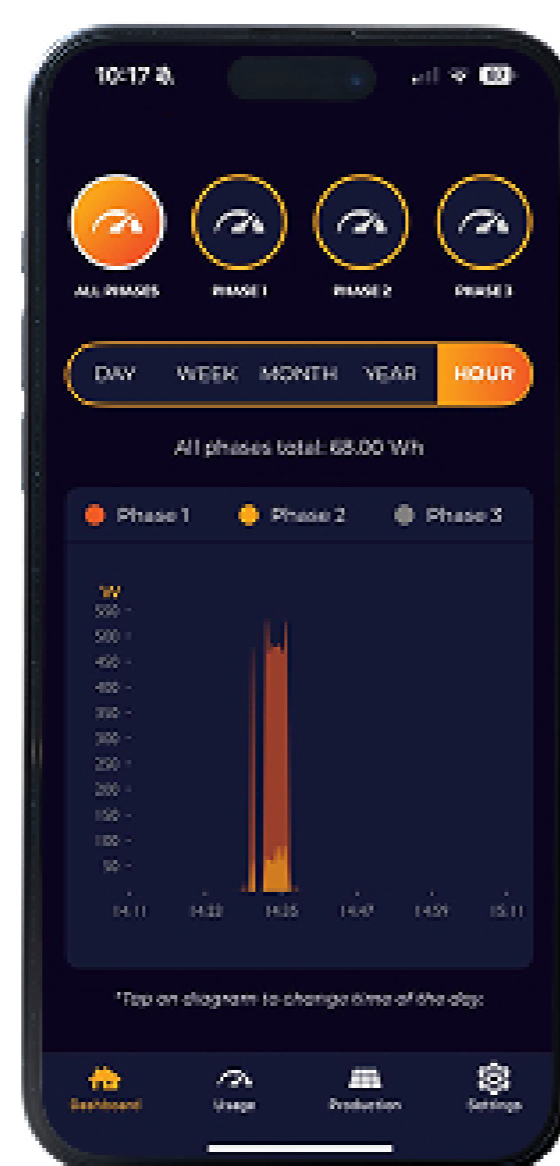

### Usage

Check power usage of your home/appliances

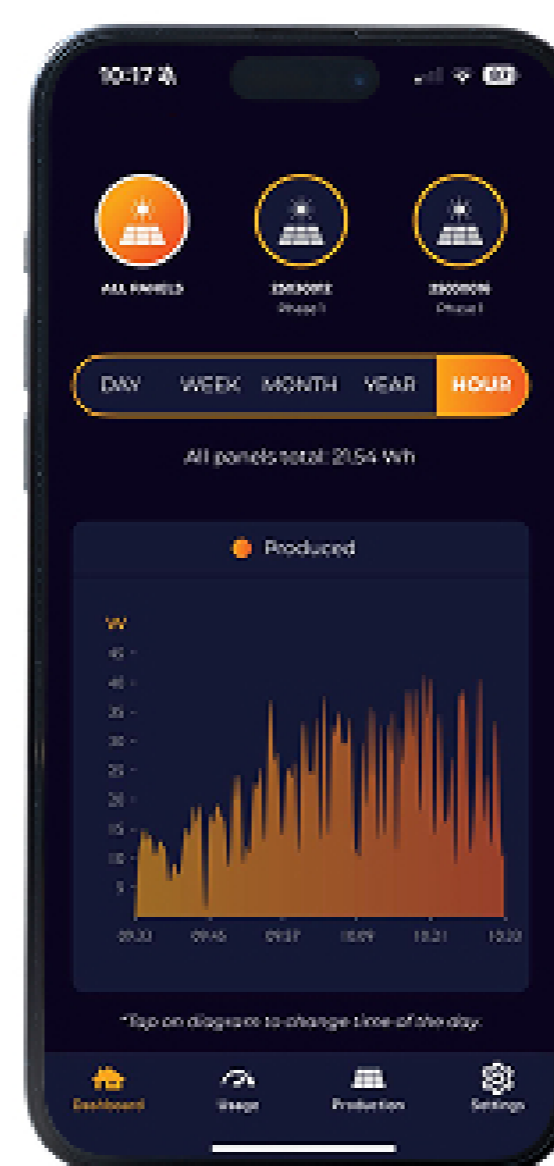

### Production

Check production of your solar kit

## 2.9 Installation – CraftStrom App



### Step 1

#### Create an Account

Open the CraftStrom App and create a user account by entering a username and password.



### Step 2

#### Add a New Device

In the settings menu, select Add New Device to begin the device setup process.

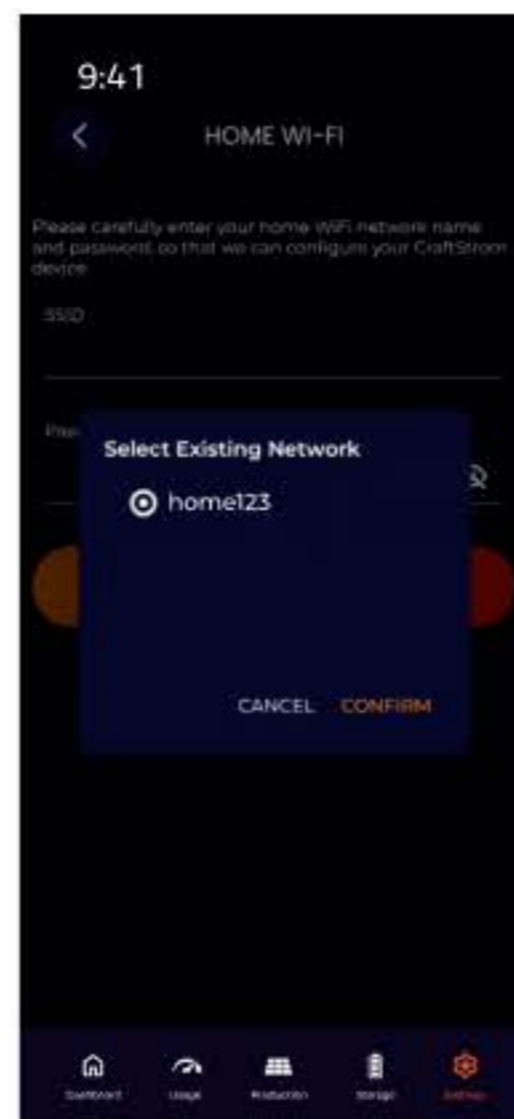

### Step 3

#### Select Wi-Fi Network

Select your home Wi-Fi network (2.4 GHz) and enter the network password.



### Step 4

#### Select Device Type

Choose Add Solar panel from the list of available devices.



### Step 5

#### Device Identification

Scan the barcode on the Inverter or manually enter the device ID.



### Step 6

#### Confirm Device ID

Verify and confirm the entered device ID to continue.

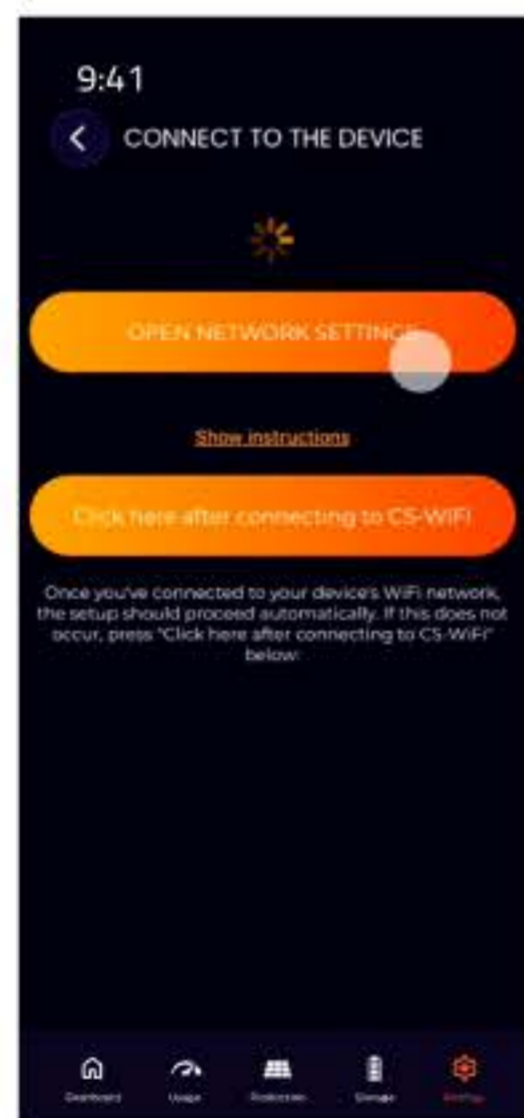

### Step 7

#### Open Network Settings

Open the network settings on your mobile device using the provided button.



### Step 8

#### Connect to Power Meter Wi-Fi

Select the Wi-Fi network named CS-WIFI to establish a temporary connection to the Inverter.



### Step 9

After selecting CS-WiFi, Return to the CraftStrom App and tap the second button.

The app will then complete the setup and display the success screen.



### Step 10

Go to DASHBOARD - scroll down to communication and expand by pressing the + button next to it. Please wait until you see a green dot under WiFi communication before you start installing the next one! You can click on the dots to see ID numbers in details...

**Note:** If the inverter does not appear on the Production page within 10 minutes, go to Settings → Devices, delete the device ID, then press and hold the RESET button next to the antenna connectors for 15 seconds. Restart the installation process.

## 2.10 Power Flow & Communication

**Craftstrom is the only company to hold a process patent for communication between AC-coupled products to balance solar production and storage in the US, Europe, and Japan.**

We use MHz communication for internal operations (with a reaction time of 0.1 seconds—essential for the Zero Backfeed option) and WiFi to display data in the app.

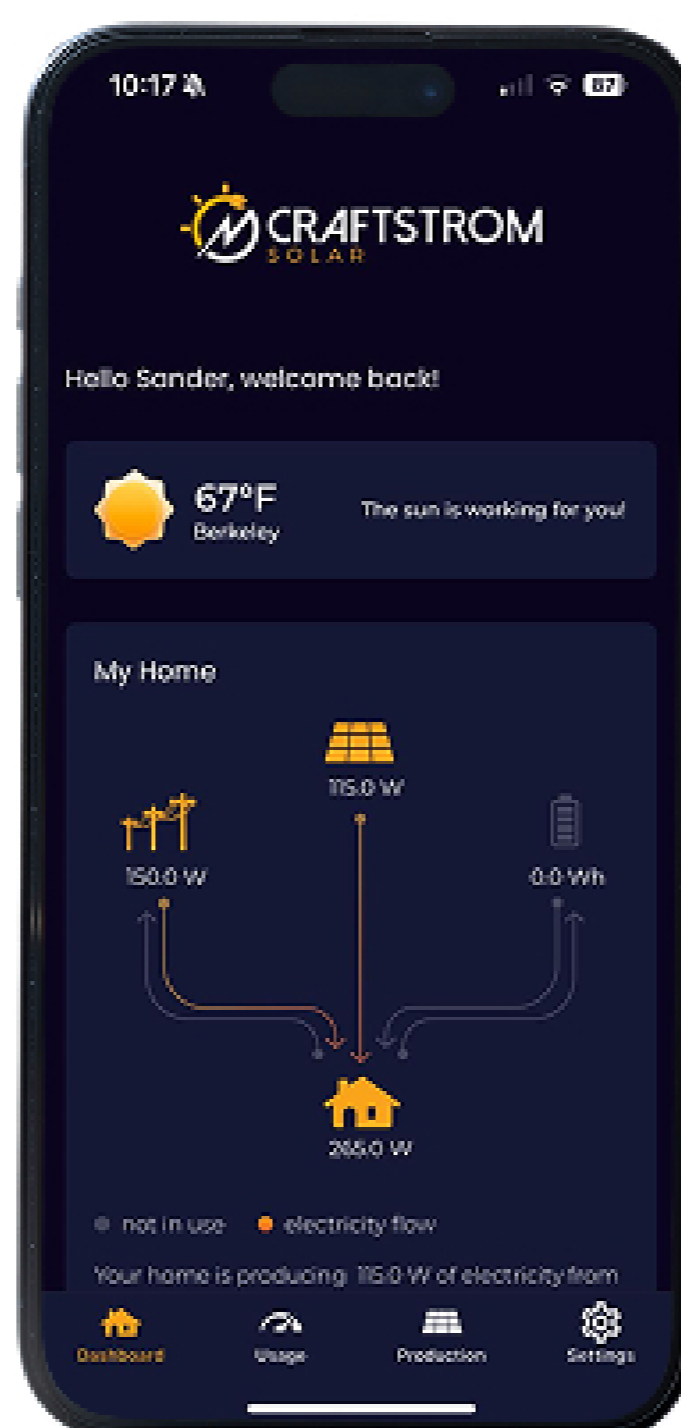
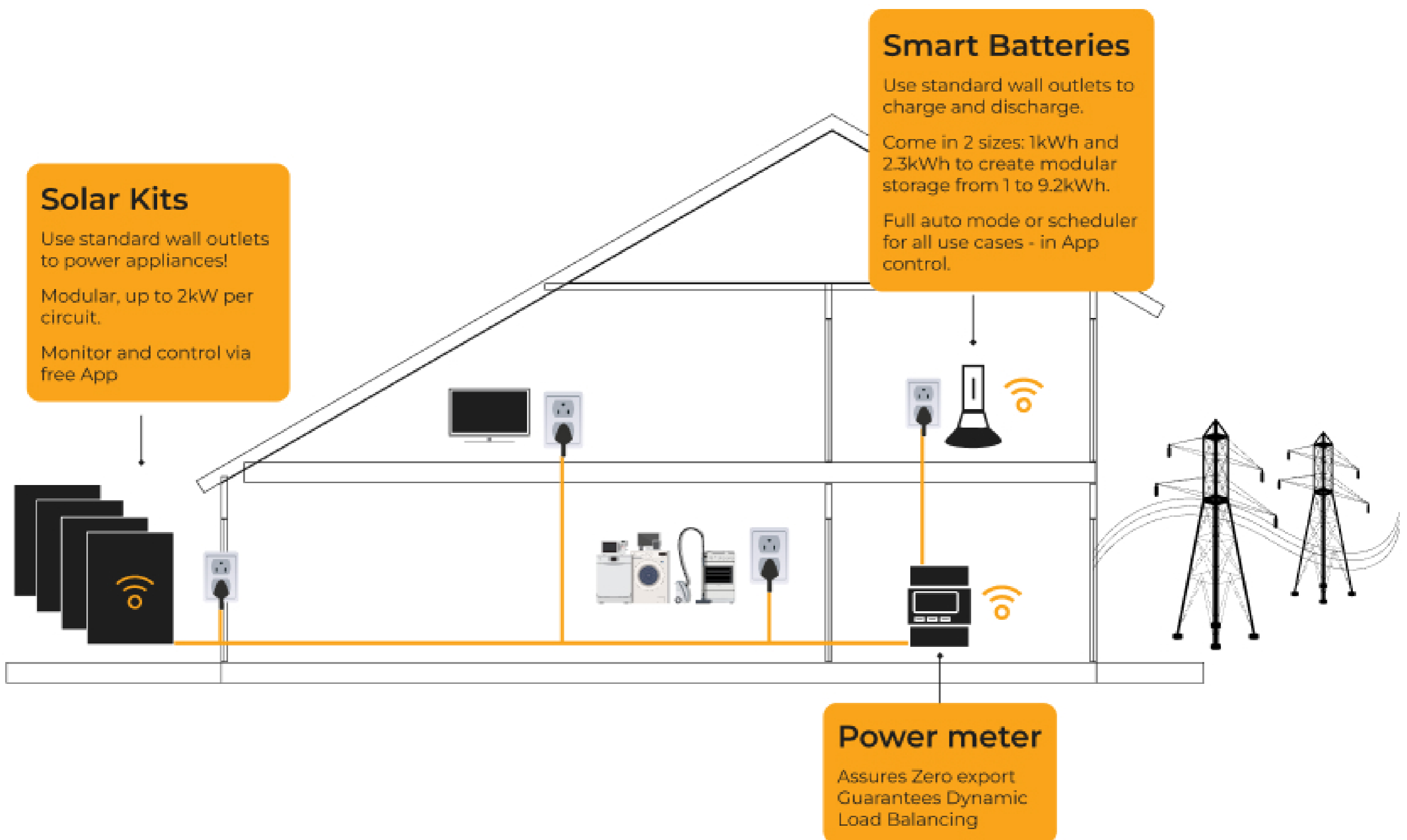

# 800W Smart Solar Kit

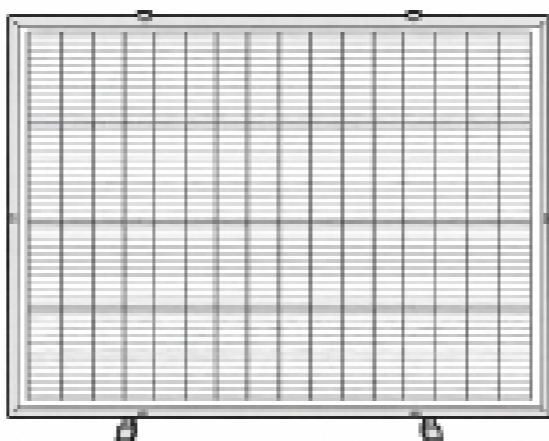
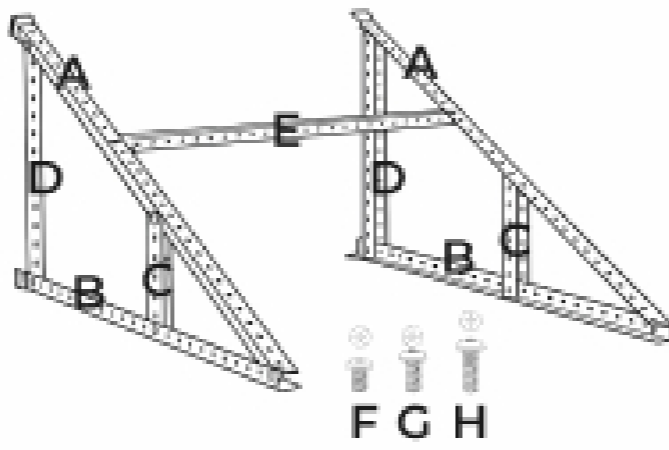
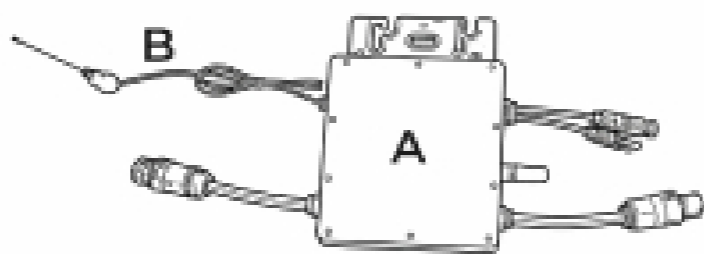
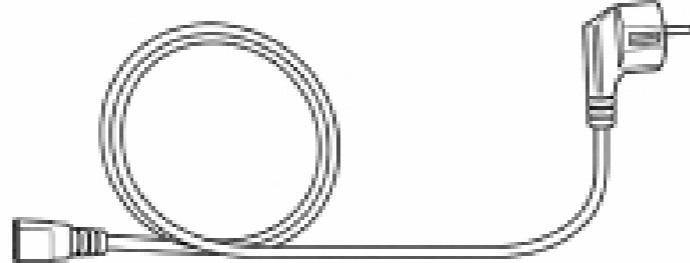
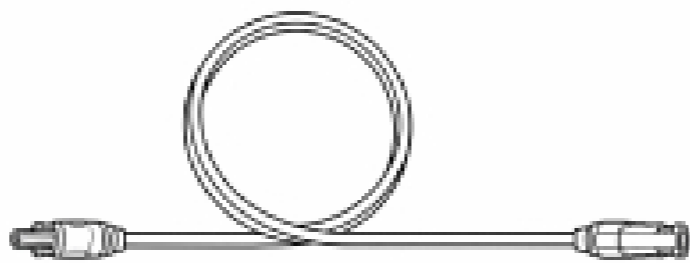
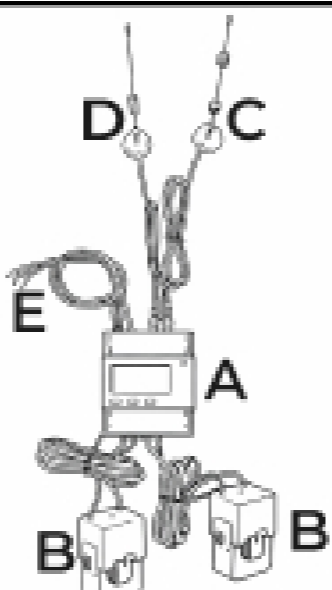
Product Package	Visual	Items	Item Quantity	Box Quantity
<b>Solar Panel Box</b>		200W Flex Solar Panel with frame	2	2
<b>Solar Mount Box</b>		A - Parallel Panel Struts - Top B - Parallel Panel Struts - Bottom C - Vertical Panel Struts - Back D - Vertical Panel Struts - Front E - Parallel Panel Strut - Middle F - Strut Screws - M5x8 G - Panel Screws - M5x12 H - Inverter Screws - M5 x 20	A - 4 B - 4 C - 4 D - 4 E - 2 F - 12 G - 4 H - 2	2
<b>Solar Micro-Inverter Box</b>		A - Micro-Inverter B - MHz-Antenna	A - 1 B - 1	2
<b>Micro-Inverter AC Cable</b>				1
<b>Micro-Inverter Conector Cable</b>				1
<b>3-Phase PowerMeter Box</b>		A - PowerMeter B - CT-Sensor Clamps C - WiFi-Antenna D - MHz-Antenna E - Power Cables	A - 1 B - 2 C - 1 D - 1 E - 3	1

# 1200W Smart Solar Kit

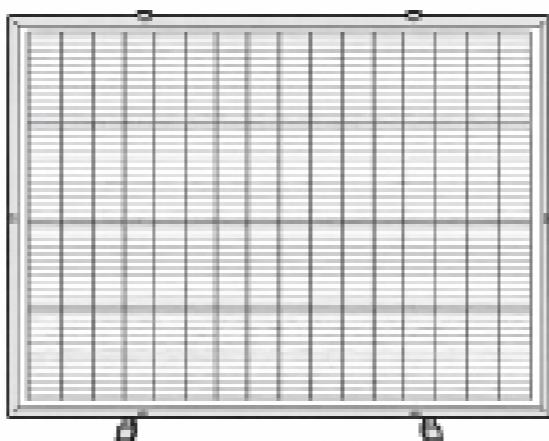
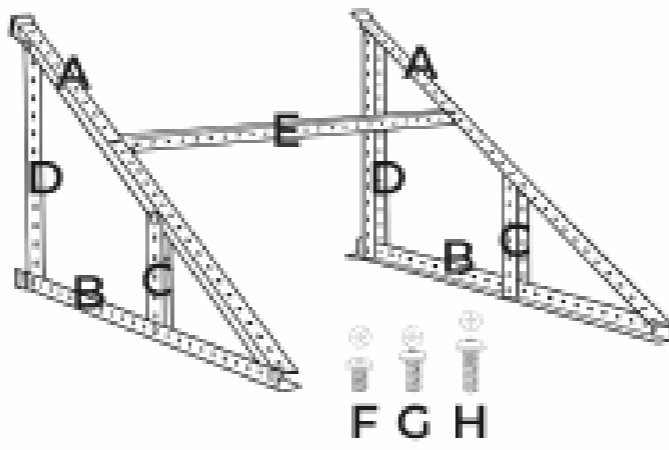
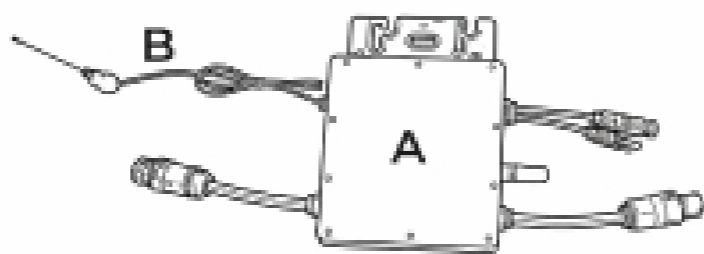
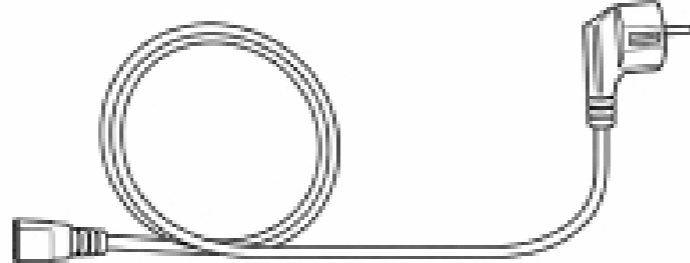
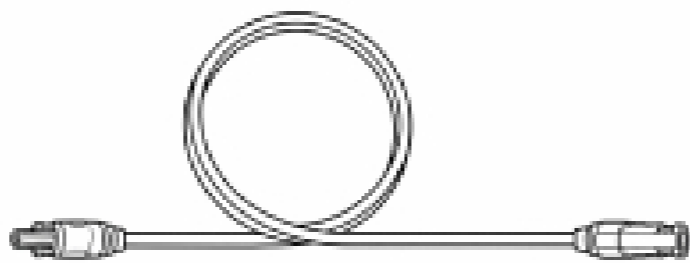
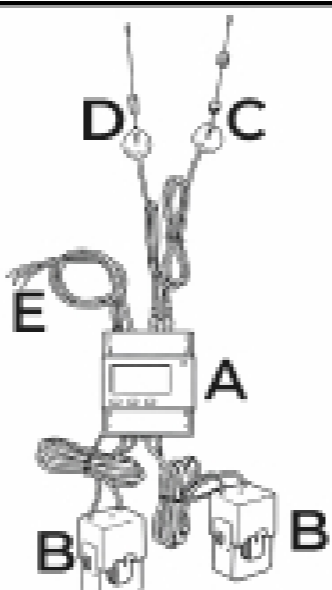
Product Package	Visual	Items	Item Quantity	Box Quantity
<b>Solar Panel Box</b>		200W Flex Solar Panel with frame	2	3
<b>Solar Mount Box</b>		A - Parallel Panel Struts - Top B - Parallel Panel Struts - Bottom C - Vertical Panel Struts - Back D - Vertical Panel Struts - Front E - Parallel Panel Strut - Middle F - Strut Screws - M5x8 G - Panel Screws - M5x12 H - Inverter Screws - M5 x 20	A - 4 B - 4 C - 4 D - 4 E - 2 F - 12 G - 4 H - 2	3
<b>Solar Micro-Inverter Box</b>		A - Micro-Inverter B - MHz-Antenna	A - 1 B - 1	3
<b>Micro-Inverter AC Cable</b>				1
<b>Micro-Inverter Conector Cable</b>				2
<b>3-Phase PowerMeter Box</b>		A - PowerMeter B - CT-Sensor Clamps C - WiFi-Antenna D - MHz-Antenna E - Power Cables	A - 1 B - 2 C - 1 D - 1 E - 3	1

# 1600W Smart Solar Kit

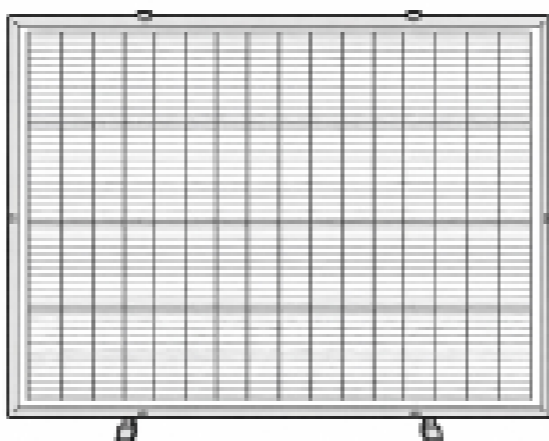
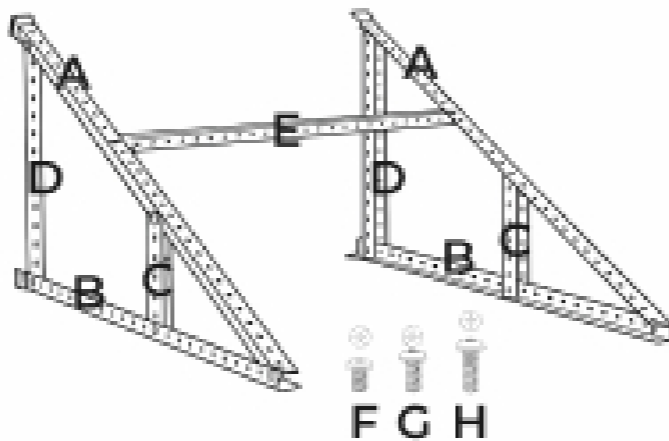
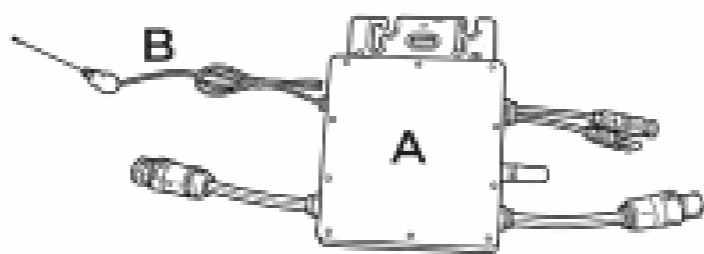
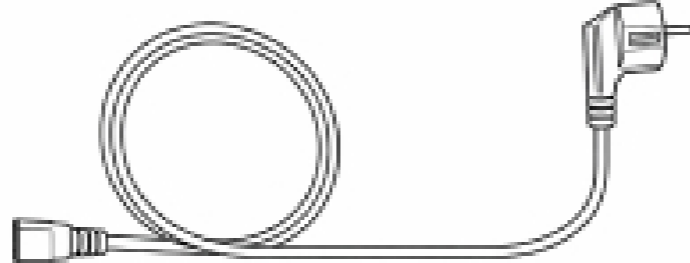
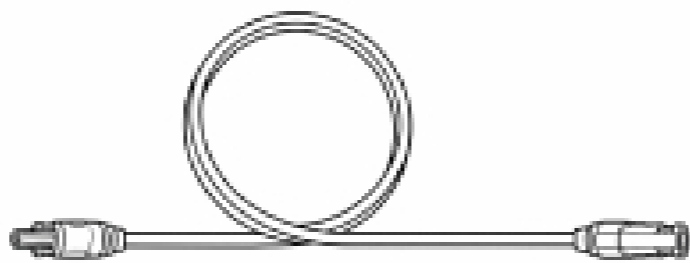
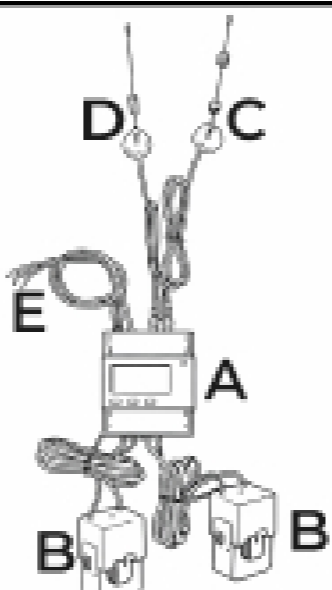
Product Package	Visual	Items	Item Quantity	Box Quantity
<b>Solar Panel Box</b>		200W Flex Solar Panel with frame	2	4
<b>Solar Mount Box</b>		A - Parallel Panel Struts - Top B - Parallel Panel Struts - Bottom C - Vertical Panel Struts - Back D - Vertical Panel Struts - Front E - Parallel Panel Strut - Middle F - Strut Screws - M5x8 G - Panel Screws - M5x12 H - Inverter Screws - M5 x 20	A - 4 B - 4 C - 4 D - 4 E - 2 F - 12 G - 4 H - 2	4
<b>Solar Micro-Inverter Box</b>		A - Micro-Inverter B - MHz-Antenna	A - 1 B - 1	4
<b>Micro-Inverter AC Cable</b>				1
<b>Micro-Inverter Conector Cable</b>				3
<b>3-Phase PowerMeter Box</b>		A - PowerMeter B - CT-Sensor Clamps C - WiFi-Antenna D - MHz-Antenna E - Power Cables	A - 1 B - 2 C - 1 D - 1 E - 3	1

## 2000W Smart Solar Kit

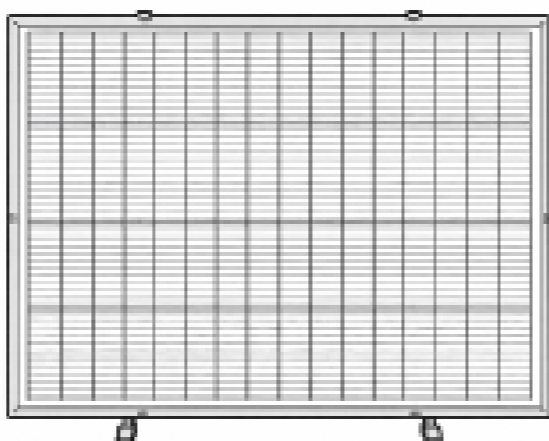
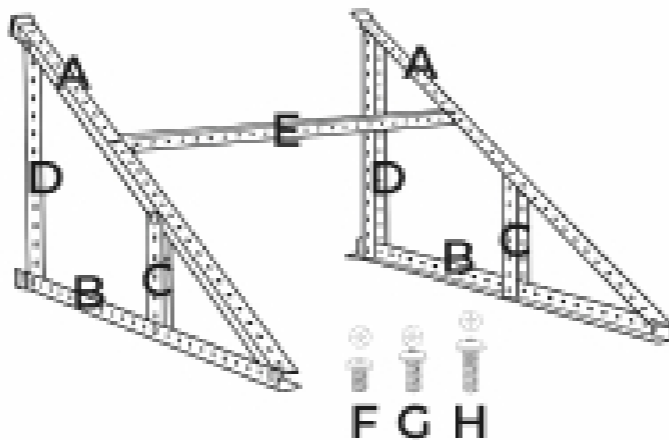
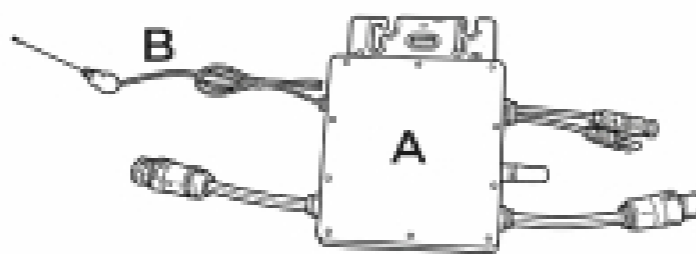
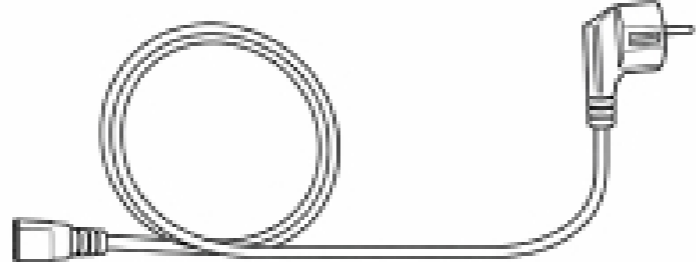
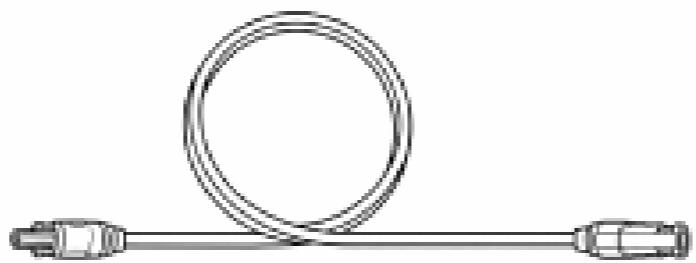
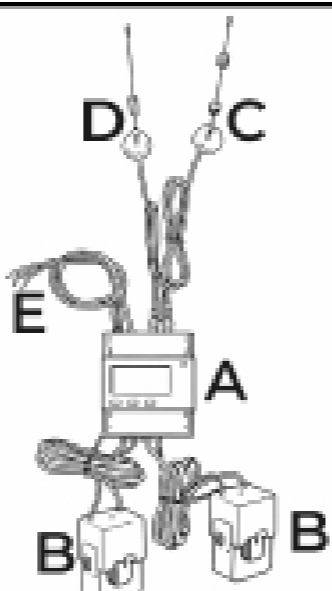
Product Package	Visual	Items	Item Quantity	Box Quantity
<b>Solar Panel Box</b>		200W Flex Solar Panel with frame	2	5
<b>Solar Mount Box</b>		A - Parallel Panel Struts - Top B - Parallel Panel Struts - Bottom C - Vertical Panel Struts - Back D - Vertical Panel Struts - Front E - Parallel Panel Strut - Middle F - Strut Screws - M5x8 G - Panel Screws - M5x12 H - Inverter Screws - M5 x 20	A - 4 B - 4 C - 4 D - 4 E - 2 F - 12 G - 4 H - 2	5
<b>Solar Micro-Inverter Box</b>		A - Micro-Inverter B - MHz-Antenna	A - 1 B - 1	5
<b>Micro-Inverter AC Cable</b>				1
<b>Micro-Inverter Conector Cable</b>				4
<b>3-Phase PowerMeter Box</b>		A - PowerMeter B - CT-Sensor Clamps C - WiFi-Antenna D - MHz-Antenna E - Power Cables	A - 1 B - 2 C - 1 D - 1 E - 3	1